

# Electrochemical Machining (ECM)

# Synopsis

- Introduction
- Principle
- Equipment
- MRR
- Tool material
- Electrolyte
- Insulation
- Electrical circuit
- Process parameters
- Advantages
- Limitations
- Applications

# Introduction

- Electrical energy used in combination with chemical reactions to remove material
- Relies on the principle of electrolysis for material removal
- Michael Faraday discovered that if two electrodes are placed in a bath containing a conducting liquid and a DC potential is applied across them, then metal can be depleted from the anode and plated on the cathode – process universally used in electroplating by making the workpiece the cathode
- In ECM, the material is removed and hence electroplating is reversed, i.e. workpiece is made the anode
- Work material must be a conductor
- Machines having current capacities as high as 40,000 A and as low as 5A are available
- Processes:
  1. Electrochemical machining (ECM)
  2. Electrochemical deburring (ECD)
  3. Electrochemical grinding (ECG)

# Principle of ECM - 1

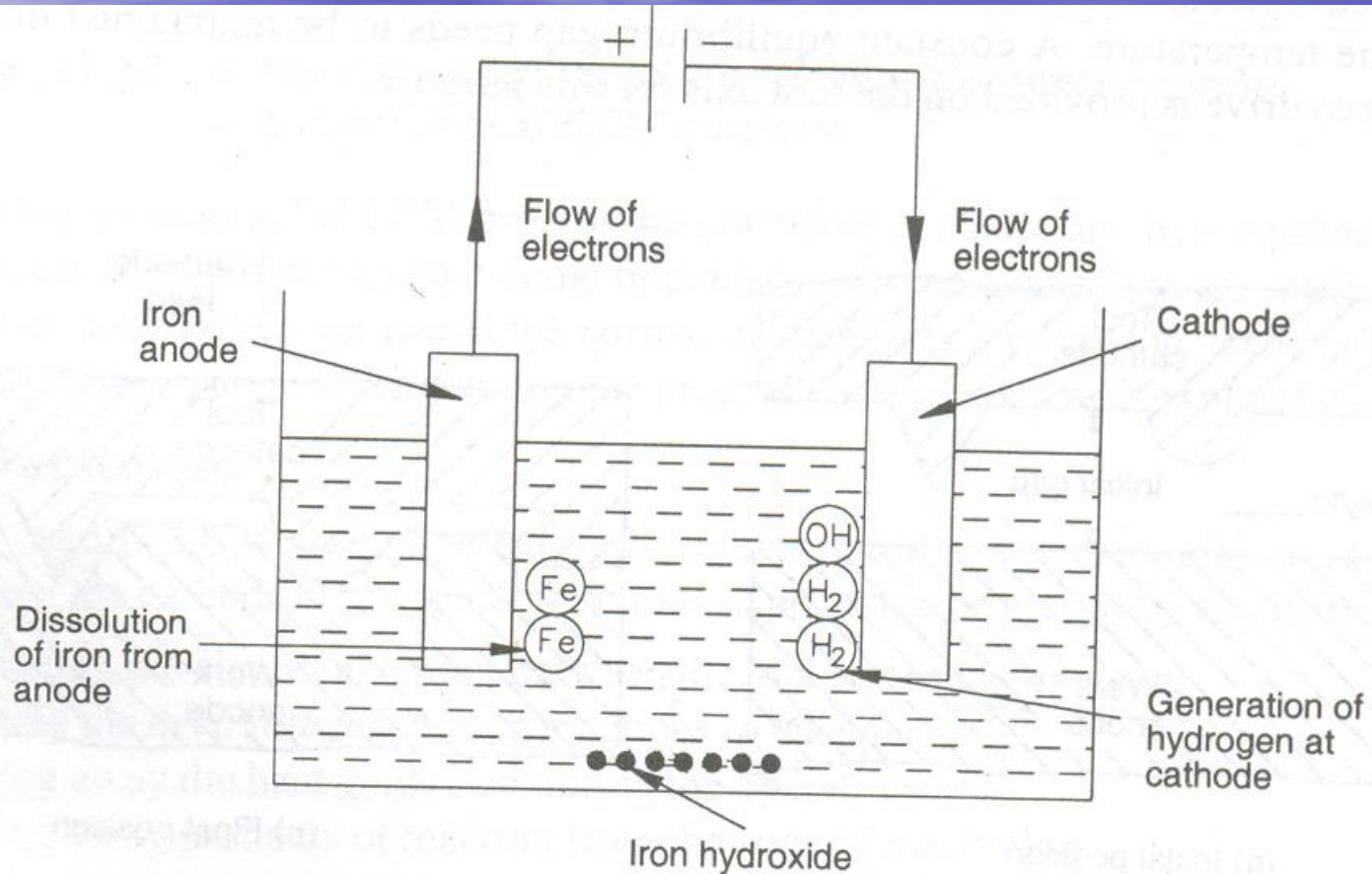

**Fig. 11.15** *Principle of electrolysis*

## Principle of ECM - 2

- Net result of electrolysis: Iron gets dissolved from the anode and forming the residue consuming electricity and water, and nothing else. Reaction products are ferric hydroxide and hydrogen gas
- Metal from the anode is dissolved electrochemically and hence the MRR based on Faraday's laws will depend upon atomic weight, valency, the current passed and the time for which the current passes
- At the cathode only hydrogen gas is evolved and no other reaction takes place, hence the shape of the cathode remains unaffected

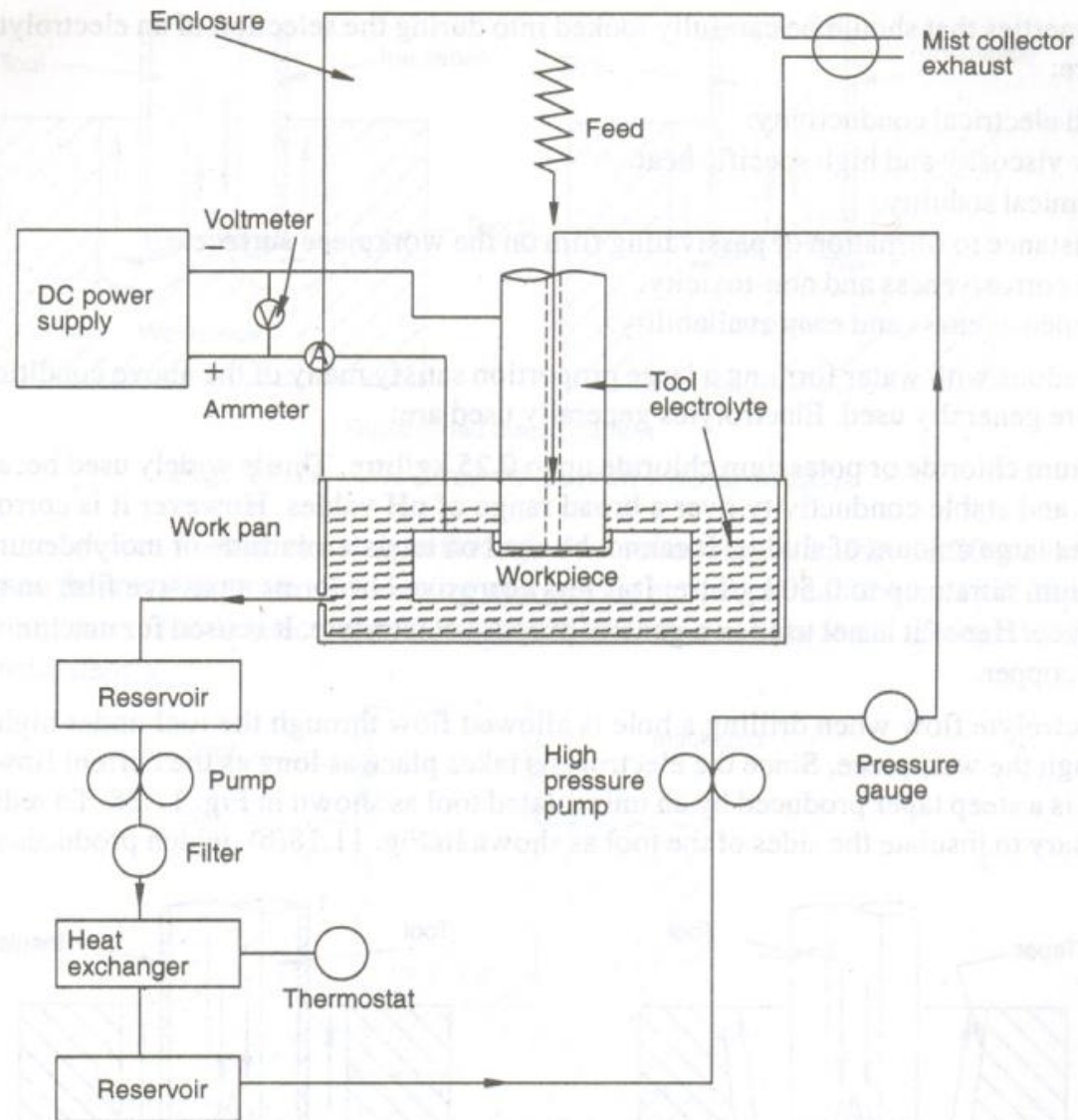

**Fig. 11.17** *Schematic diagram of the various elements present in a commercial ECM machine*

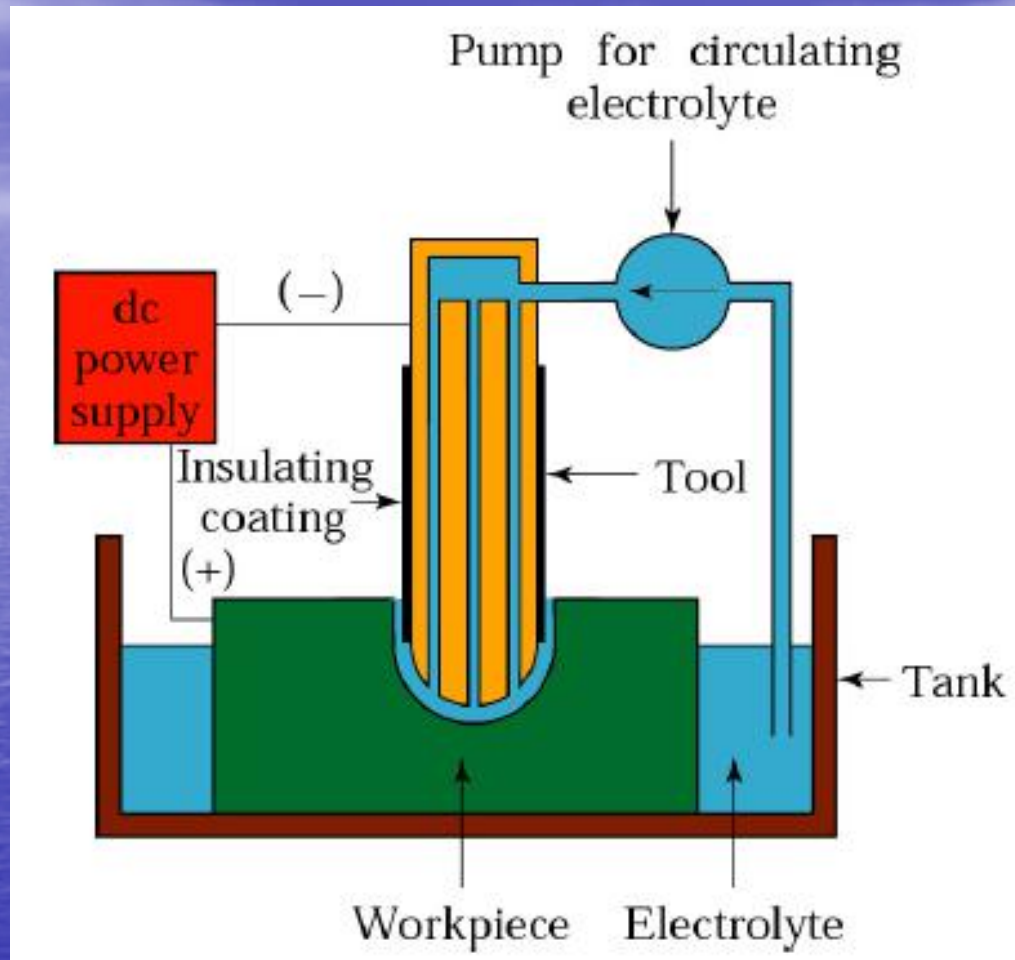

Fig : Schematic illustration of the electrochemical-machining process. This process is the reverse of electroplating.

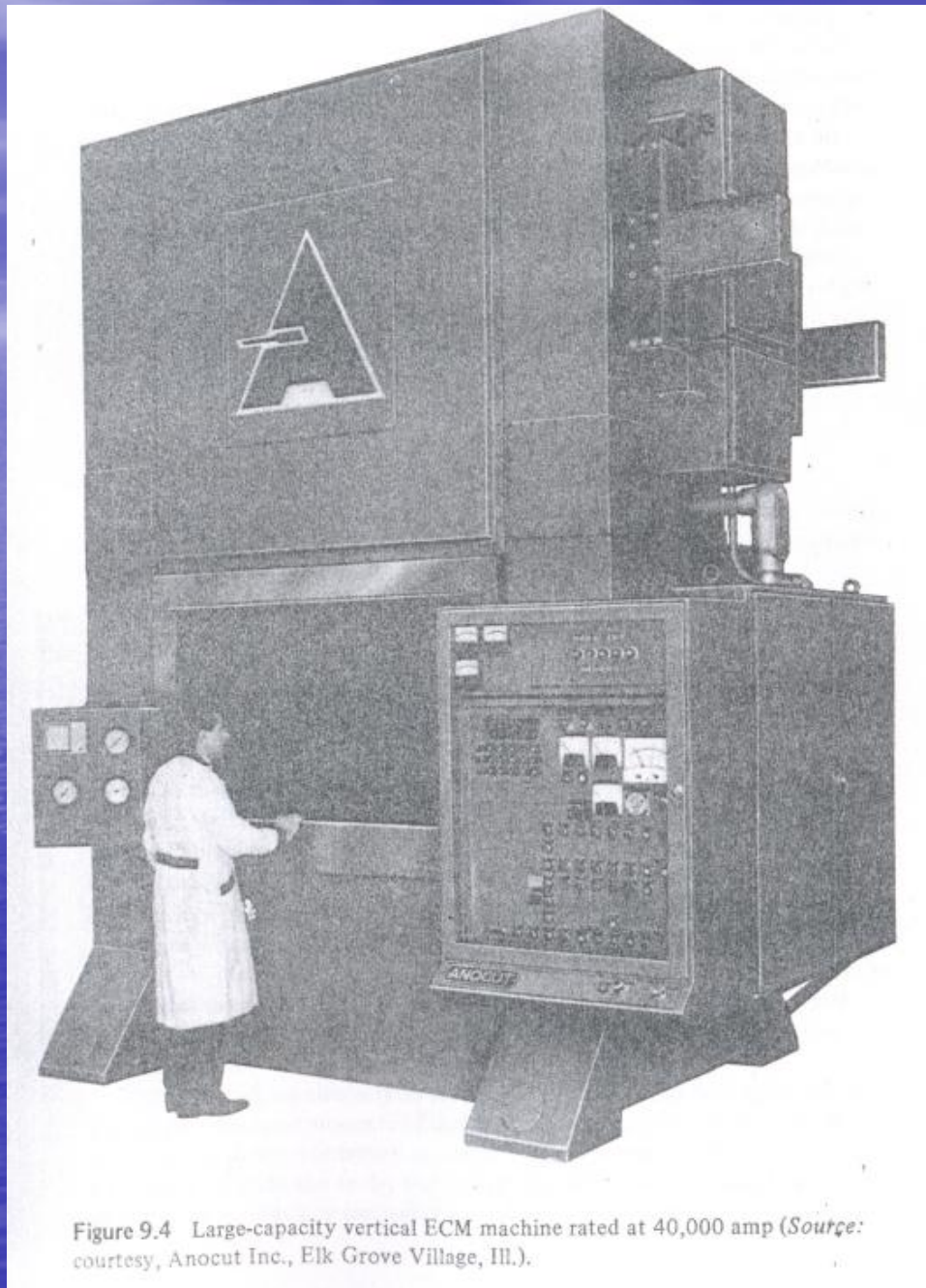

Figure 9.4 Large-capacity vertical ECM machine rated at 40,000 amp (Source: courtesy, Anocut Inc., Elk Grove Village, Ill.).



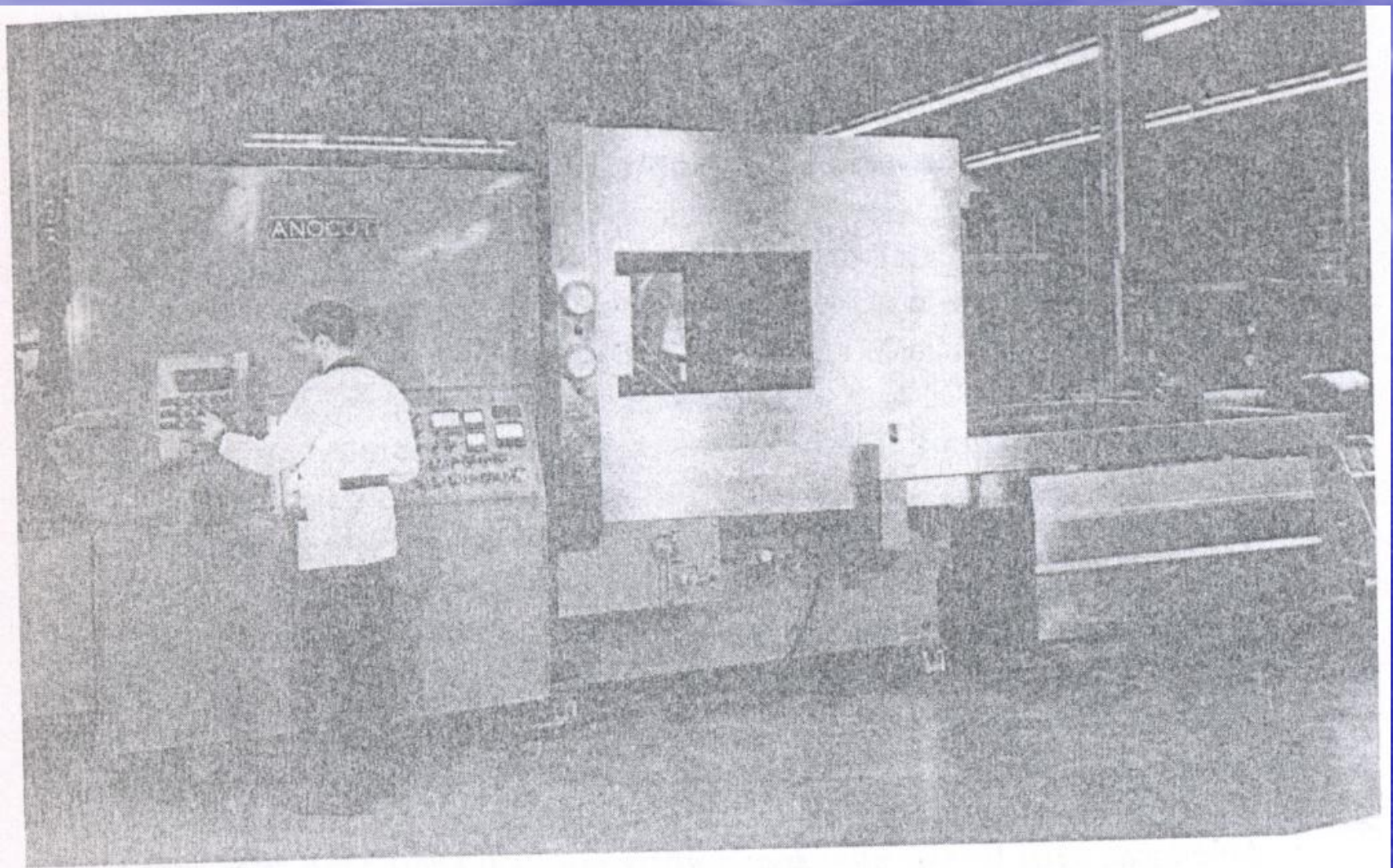

Figure 9.5 Horizontal configuration, 20,000-amp ECM machine (*Source: courtesy, Anocut Inc., Elk Grove Village, Ill.*).

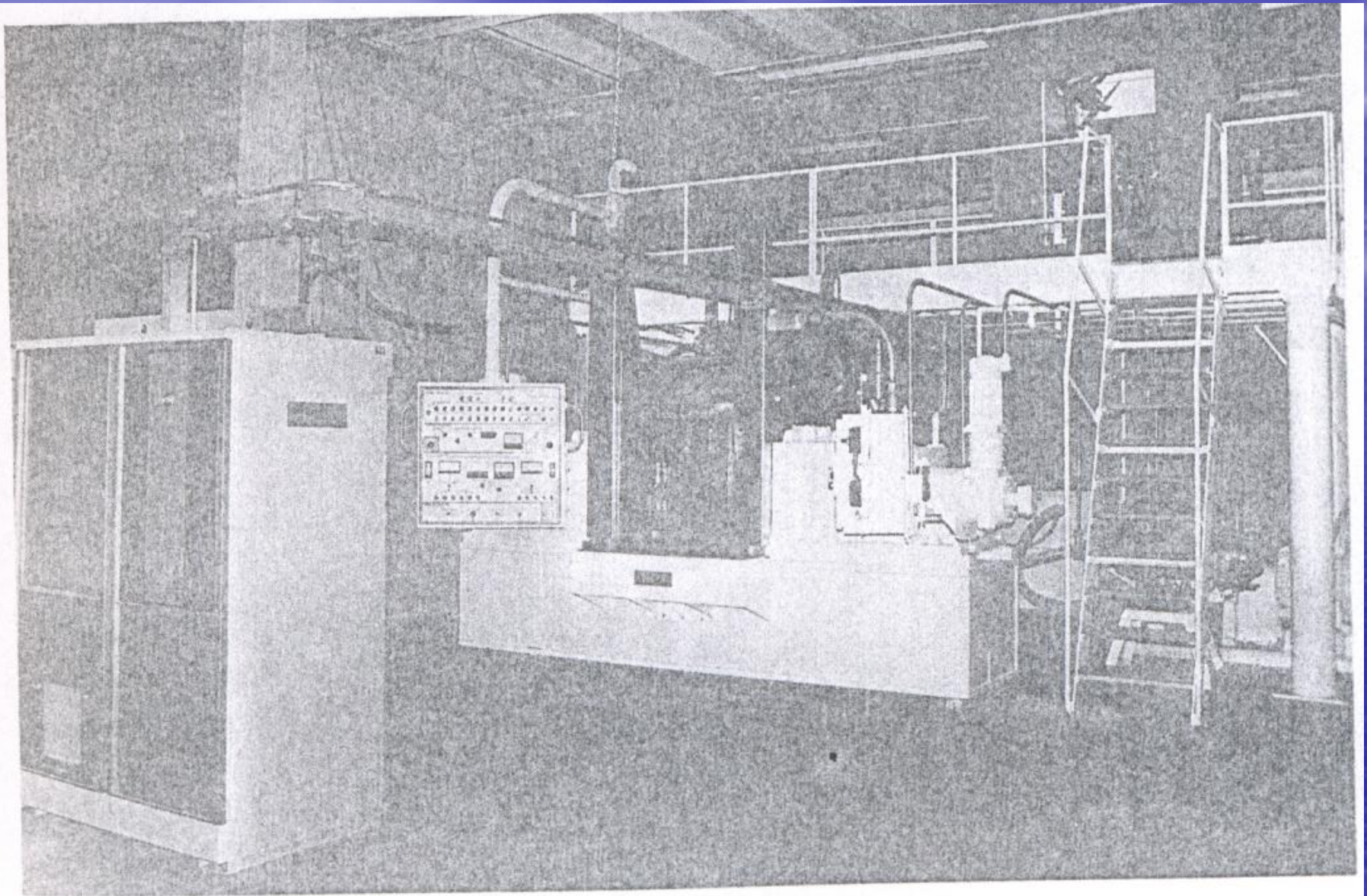

Figure 9.6 A CNC tri-ram ECM system used for machining turbine engine blades (*Source:* courtesy, Chemform, Pompano Beach, Fla).

# Sub-systems

1. Power source
  - High value DC (may be as high as 40,000A) and a low value of electric potential (in the range of 5-25V) across the IEG is desirable
  - With the help of a rectifier and a transformer, three phase AC is converted to low voltage, high current DC
  - Silicon controlled rectifiers (SCR) are used both for rectification as well as for voltage regulation
2. Electrolyte supply and cleaning system
  - Consists of pump, filters, piping, control valves, heating or cooling coils, pressure gauges and a storage tank
3. Tool and tool-feed system
4. Workpiece and work-holding system
  - Only electrically conductive workpieces can be machined by this process – the chemical properties of anode material largely govern the MRR
  - Workholding devices are made of electrically non-conductive materials having good thermal stability, and low moisture absorption properties. For example, graphite fibres-reinforced plastics, plastics, perspex, etc

# Operation

- Material is depleted from anode workpiece (positive pole) and transported to a cathode tool (negative pole) in an electrolyte bath
- Electrolyte flows rapidly between the two poles to carry off depleted material, so it does not plate onto tool
- Electrode materials: Aluminium, Cu, brass, titanium, cupro-nickel and stainless steel
- Tool has inverse shape of part
- Tool size and shape must allow for the gap

# Process capabilities

- Used to machine complex cavities in high strength material
- Applications in aerospace industry, jet engines parts and nozzles
- ECM process gives a burr free surface
- No thermal damage
- Lack of tool forces prevents distortion of the part
- No tool wear
- Capable of producing complex shapes and hard materials

# Tool material

Properties expected out of the tool material:

- High electrical and thermal conductivity
- Good stiffness
- Easy machinability - particularly important if complex shaped tools are required
- High corrosion resistance - to protect itself from the highly corrosive electrolyte solution
- Rigidity - Rigidity of the tool construction and material is important because the high pressure can cause deflection of the tool
- Easily available

Generally aluminium, copper, brass, bronze, carbon, copper-manganese, copper-tungsten, titanium, cupro-nickel and stainless steel are used

# Tool design considerations

Two major aspects of tool design:

1. Determining the tool shape so that the desired shape of the job is achieved
2. Other considerations such as electrolyte flow, insulation, strength and fixing arrangements
  - Modification of the tool profile to get the required final surface is relatively complex - FEM can be used to get the final tool design
  - Designer must determine the nature and the extent of the required deviation or gap allowances from the mirror image configuration, while providing for a uniform and sufficiently high flow rate of electrolyte in the gap to allow a practical MRR
  - Tool dimensions must be slightly different from the nominal mirror dimensions of the completed part to allow for ECM overcut
  - Part and the cathode must have adequate current-carrying capacity
  - ECM cell must have strength and rigidity to avoid flutter and arcing

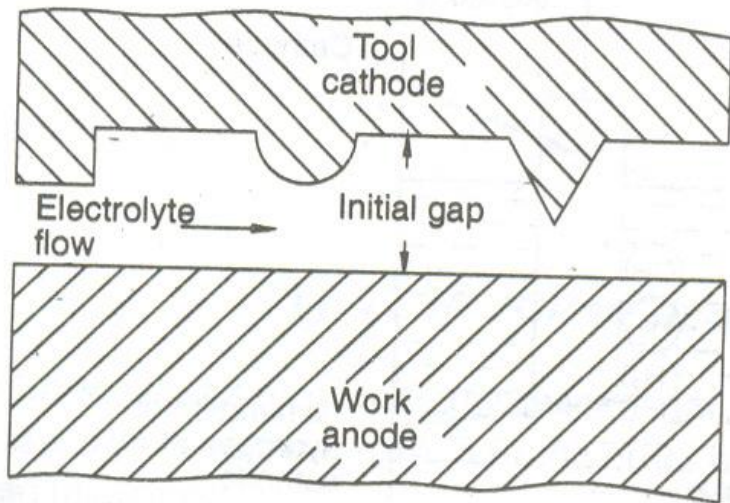

(a) Initial position

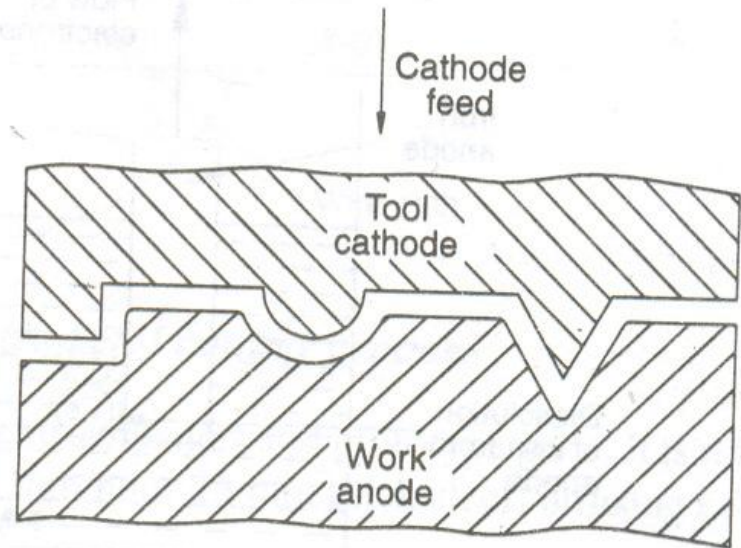

(b) Final position

**Fig. 11.16** *Complimentary shape produced by ECM*



# Tool design types

- Most common – open-flow type
- Cross-flow type for external machining
- Because of the interaction of working-tip shape and dimensions, location of insulation, current density and feed rate, the design of tools for machining complex shapes requires understanding of fluid flow, electrical and electrochemical principles as well as experience and ingenuity
- Although tool design may be difficult and time consuming, the cost of additional or replacement ECM tooling is usually much less than that for conventional machining

## Hole-sinking tool of the open-flow type with insulated side wall

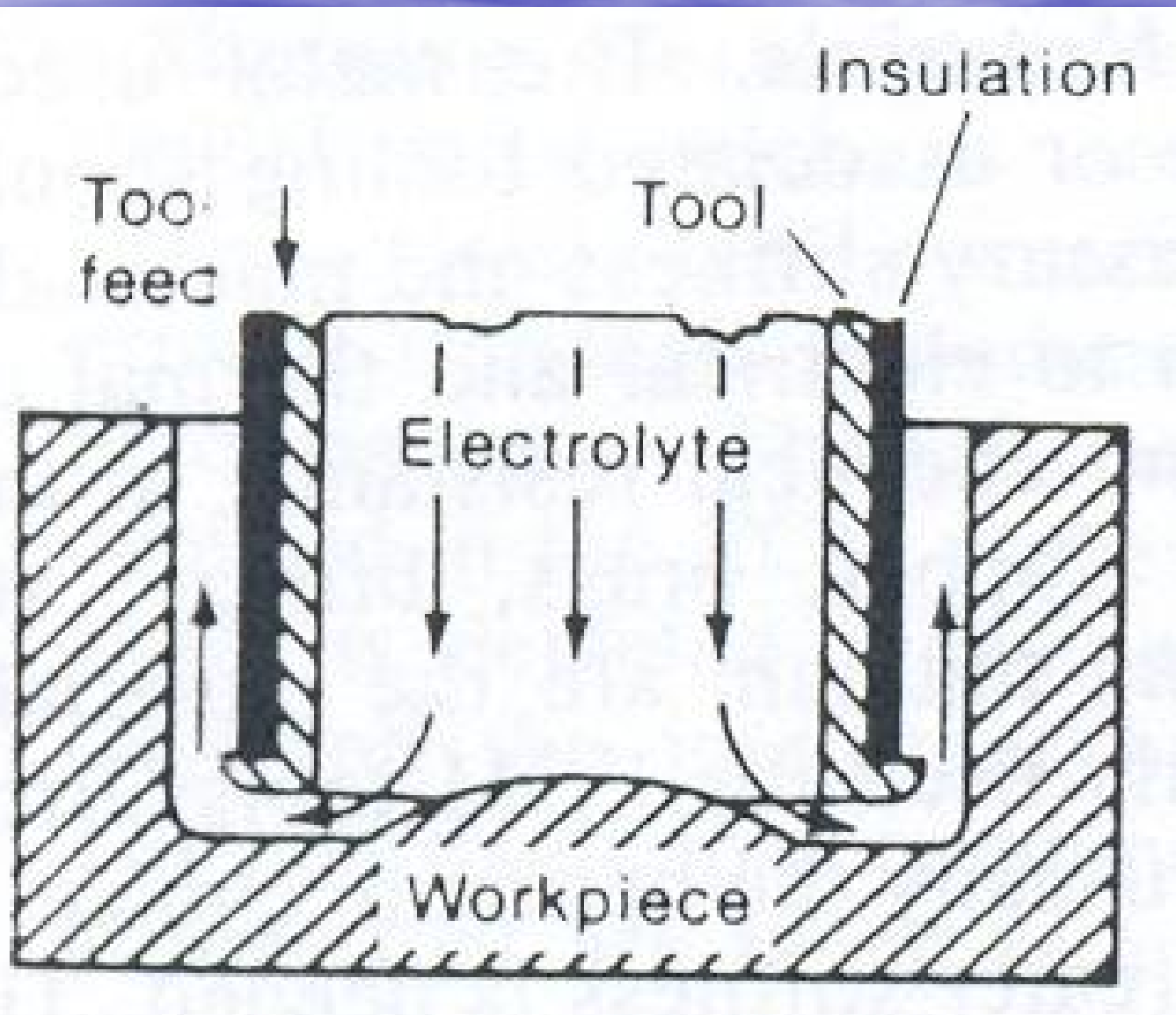

# Dual external cutting tool, cross-flow type

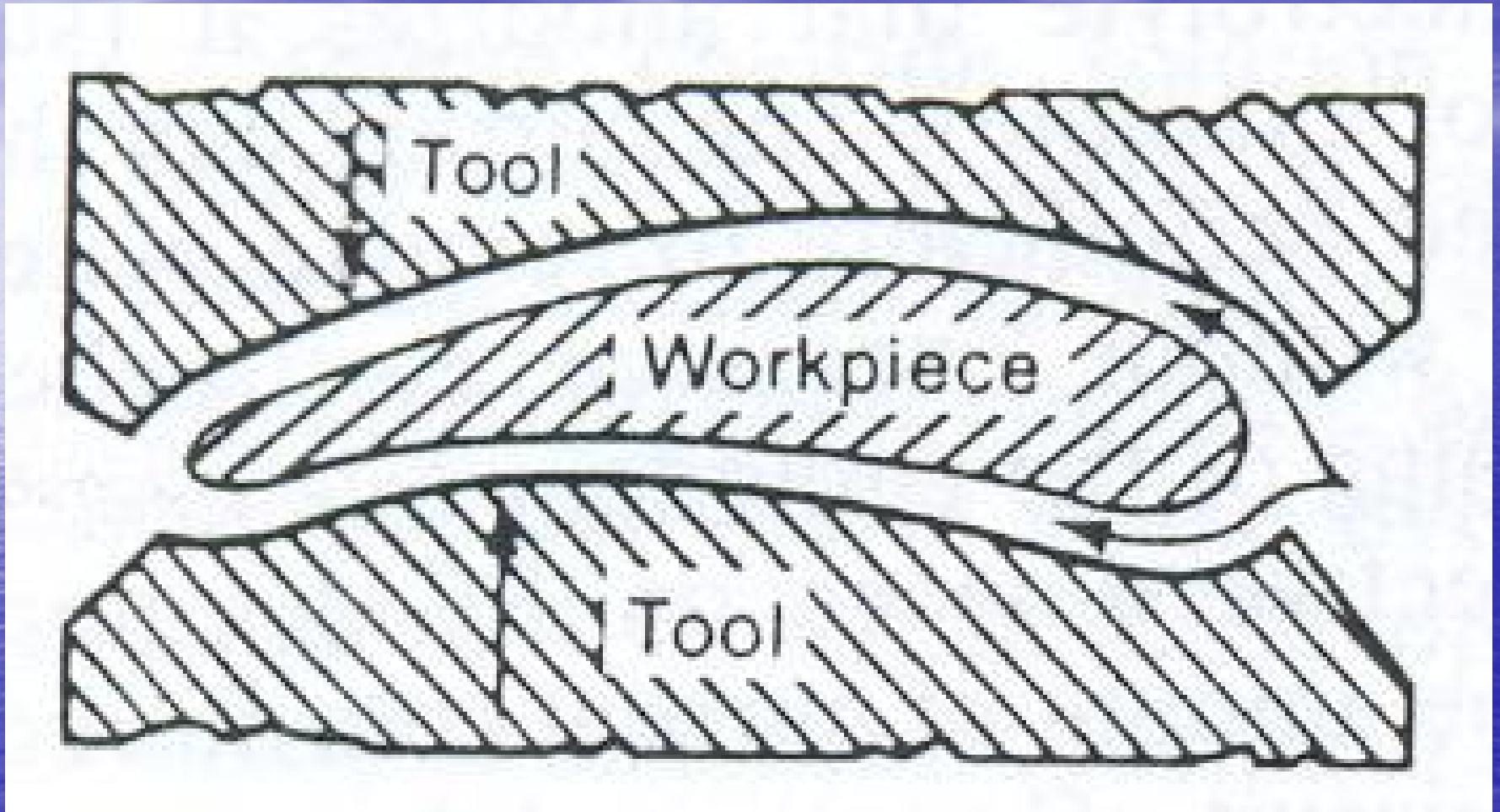

# Tool for tapering a predrilled hole

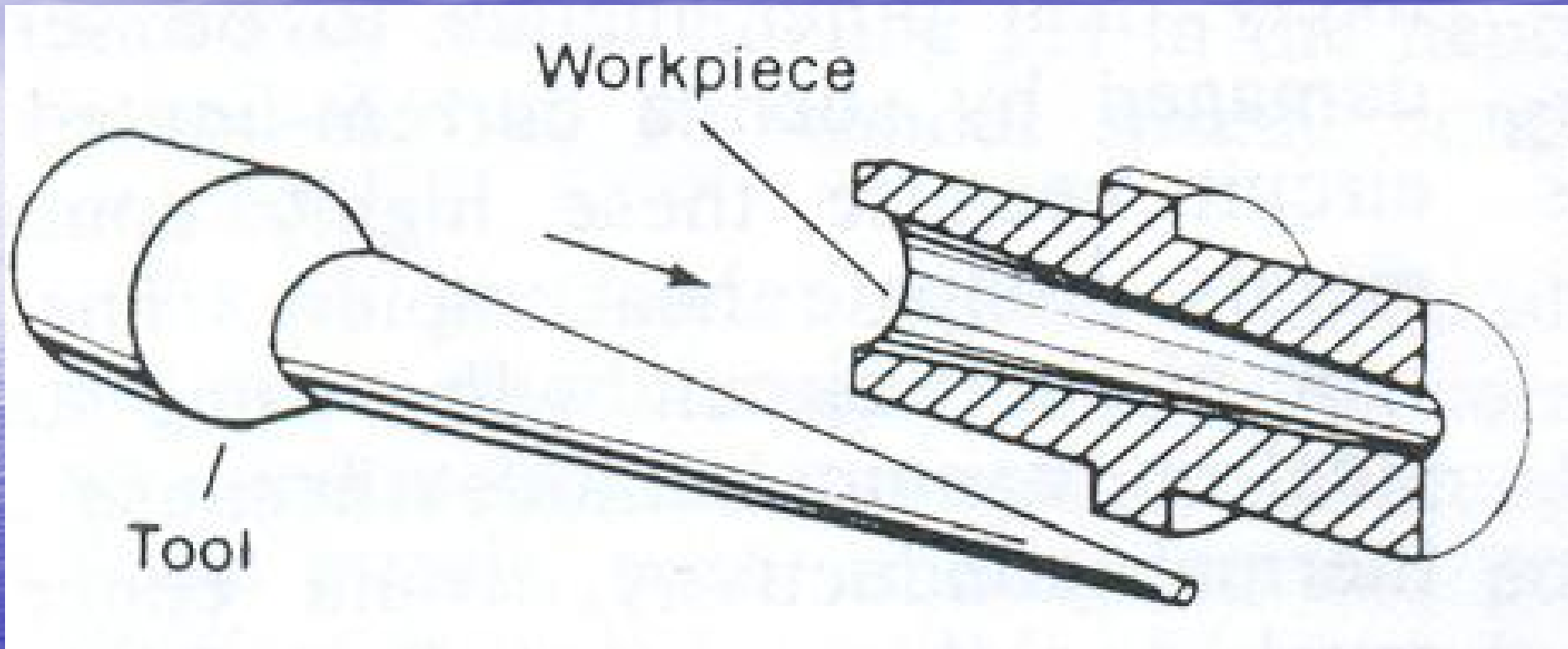

# Tool for sinking a stepped through hole

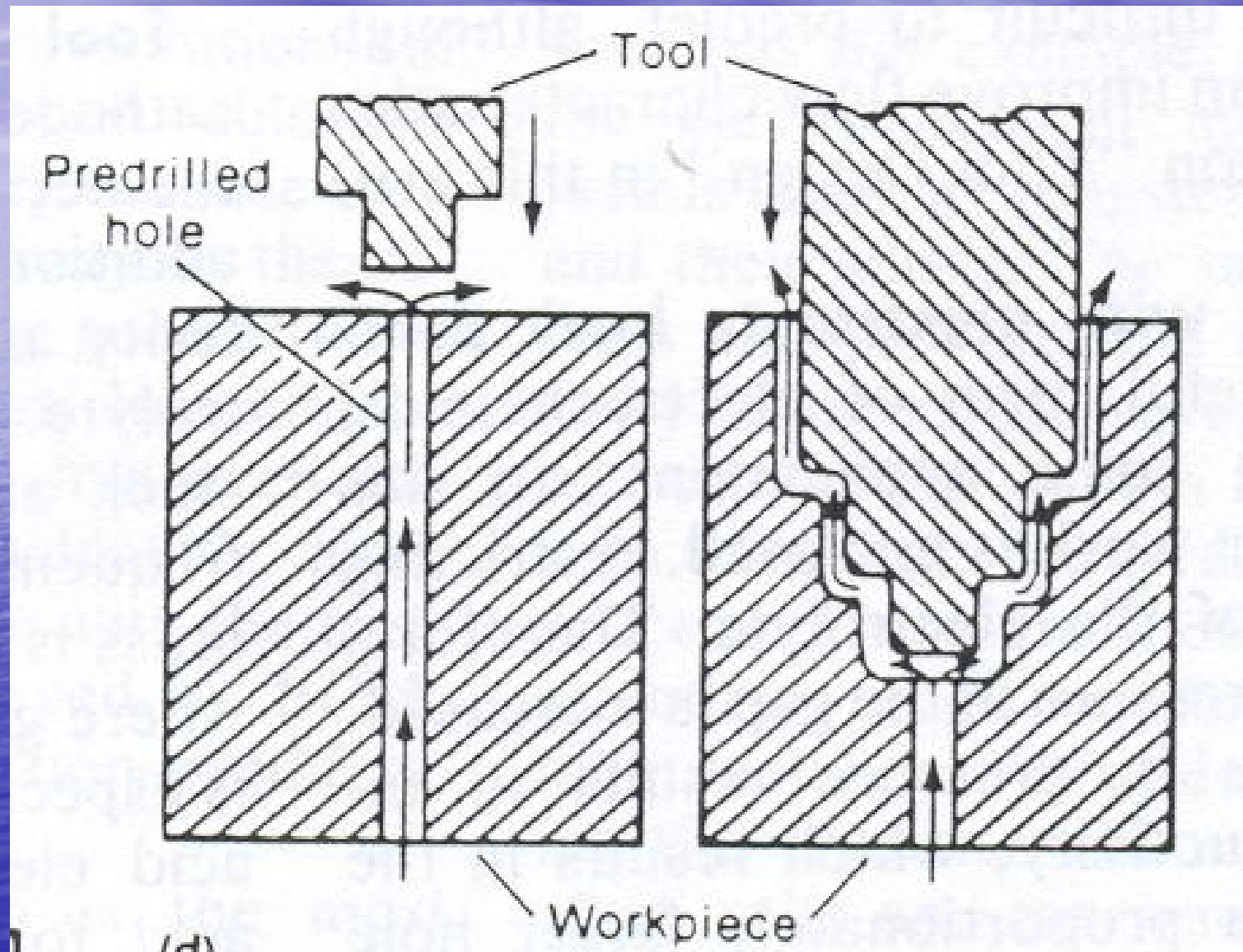

# Tool for enlarging interior section of a hole

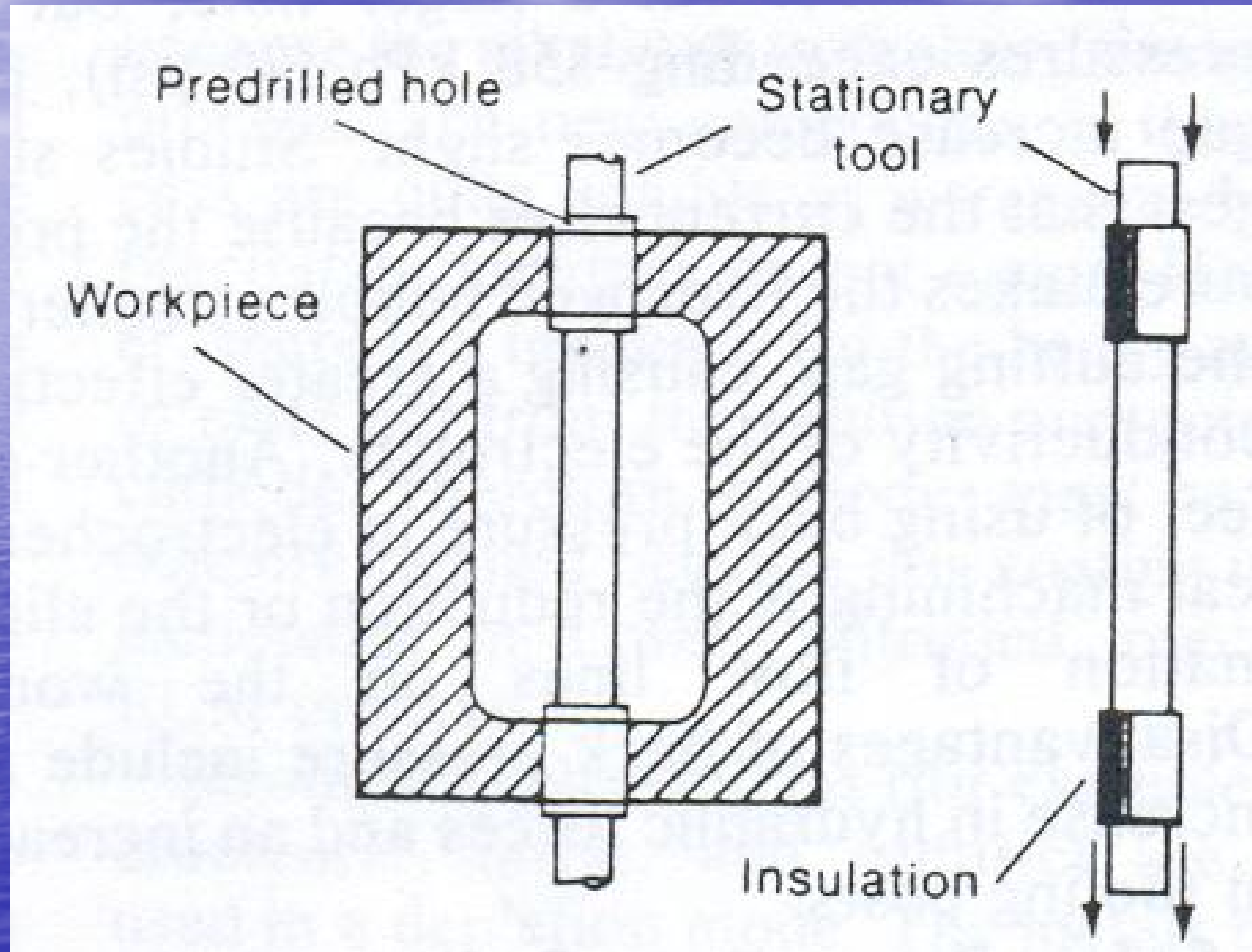

Open-flow cathode used to generate the outside diameter wall and leave an embossment

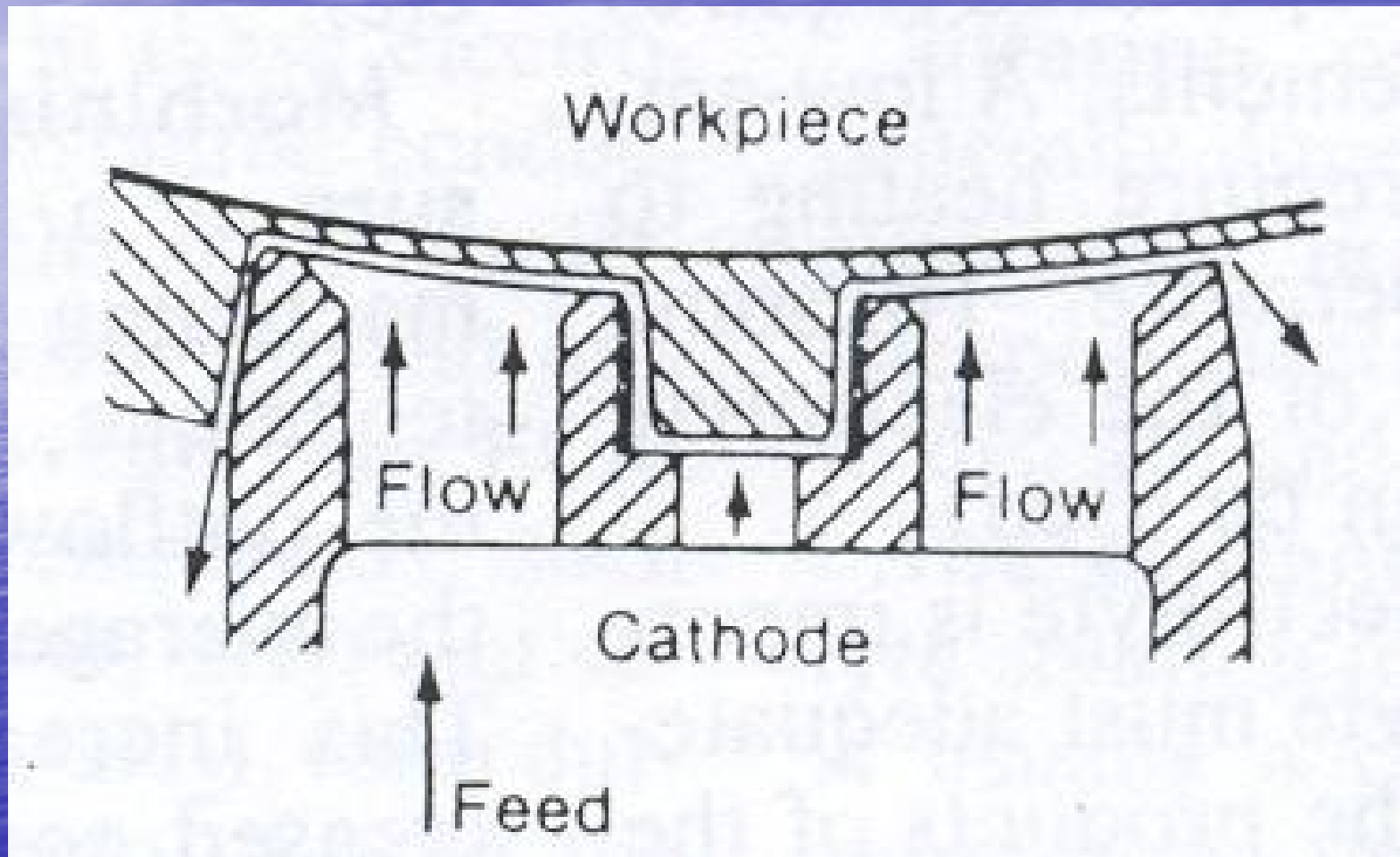

Cross-flow tool used to generate ribs on a surface without leaving flow lines on the part

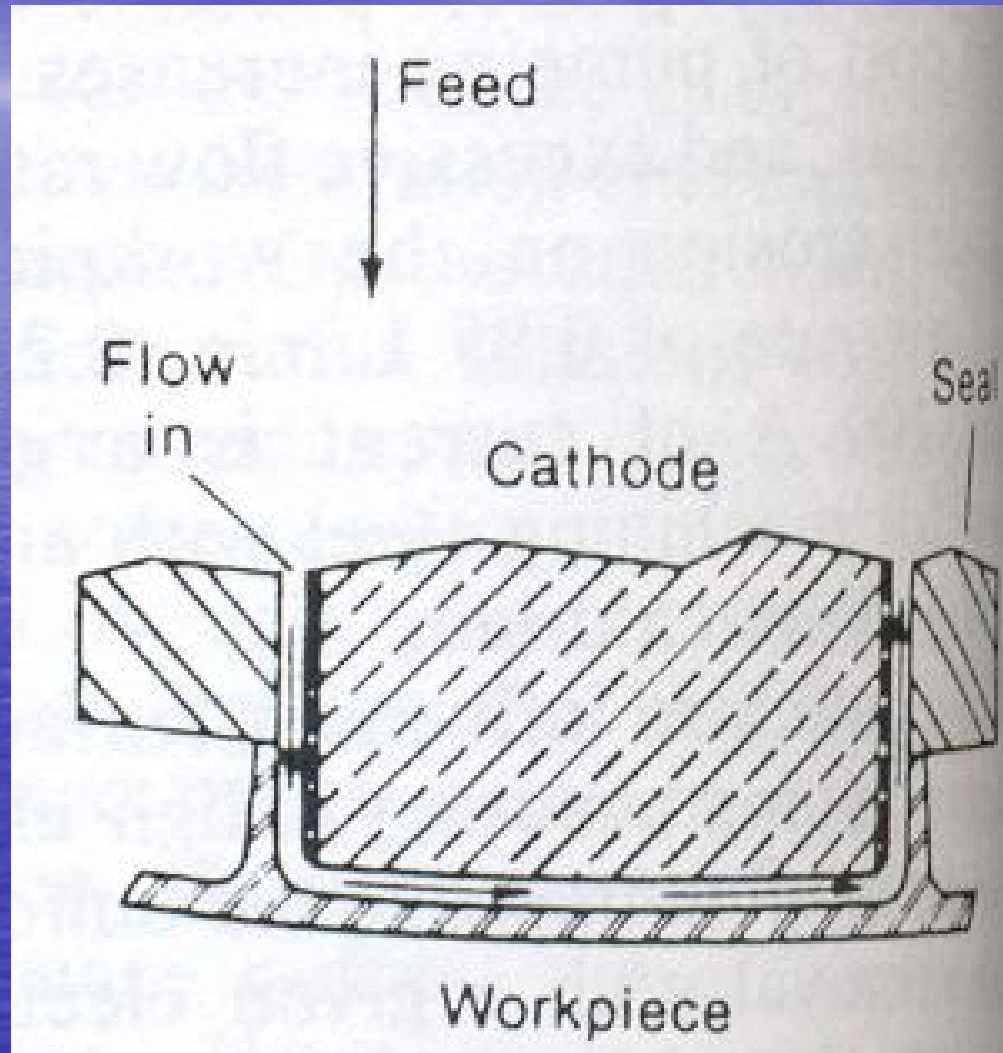



# Electrolyte

Electrolytes used in ECM should be carefully selected so that they provide the necessary reactions without plating the cathode

Functions expected:

- Completing the electrical circuit between the tool and the workpiece
- Allowing the desirable machining reactions to take place
- Carrying away the heat generated during the operation
- Carrying away products of reaction from the zone of machining

## Desirable electrolyte properties

- High electrical conductivity - easy ionisation
- Low viscosity - for easy flow
- High specific heat - to carry more heat
- Chemical stability - to be chemically neutral or does not disintegrate during the reaction
- Resistance to formation of passivating film on the workpiece surface
- Non corrosiveness and non-toxicity
- Inexpensiveness and easy availability

Salt solutions with water forming a large proportion satisfy many of the above conditions and therefore they are generally used

# Electrolytes

Types: Sludging and Nonsludging

1. Sludging: solutions of typical salts such as NaCl
  - Salts are generally not depleted and they provide substantial conductivity to the solutioning water
  - Hydroxide ions combine with the metal ions that are being removed thus forming insoluble reaction products or sludge
  - a. Sodium chloride or potassium chloride up to 0.25kg/litre
    - Widely used because of its low cost and stable conductivity over a broad range of pH values
    - However its corrosive and produces large amount of sludge
  - b) Sodium nitrate up to 0.50kg/lit
    - Less corrosive but forms a passive film on the workpiece surface – hence not used as a general purpose electrolyte
    - Used for machining aluminium and copper
2. Nonsludging:
  - Strong alkali solutions for e.g. NaOH are used in ECM of heavy metals (such as tungsten and molybdenum) and their alloys
  - Salts are depleted because the sodium ions of the salt join with the metals being removed
  - New compounds such as sodium tungstate form during the process and makeup of both the alkali salts and water are required
  - The new compounds in the process are quite soluble in water and heavy precipitate volumes do not occur. However, there is a tendency for the heavy metals to plate onto the cathode

## Design for electrolyte flow

Need for sufficient electrolyte flow between the tool and the workpiece:

- To carry away the heat and the products of machining
- To assist the machining process at the required feed rate, producing a satisfactory surface finish
- Cavitation, stagnation and vortex formation should be avoided since these lead to bad surface finish
- There should be no sharp corners in the flow path. All corners in the flow path should have a radius

When drilling a hole – flow through the hole under high pressure and exits through the workpiece

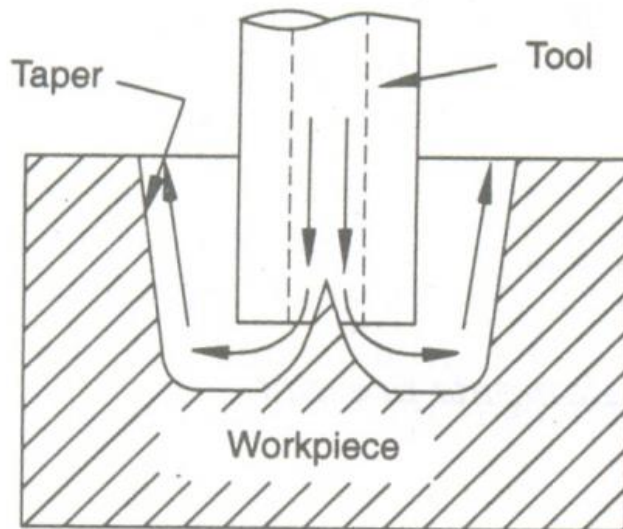

(a) Electrolyte through electrode

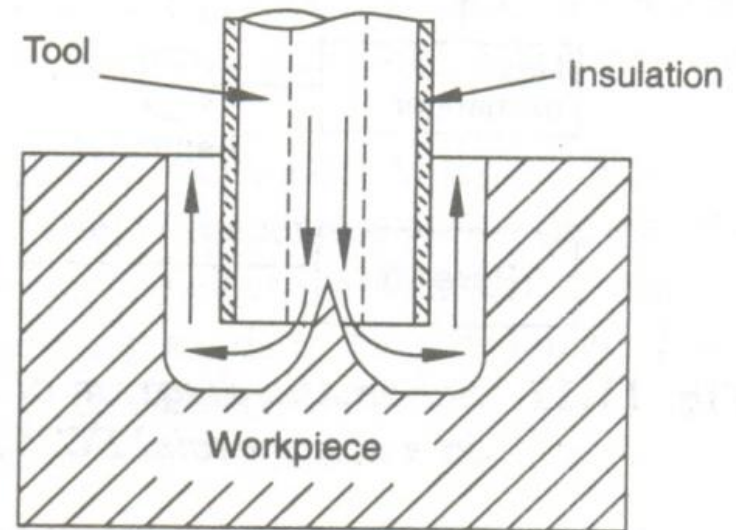

(b) Insulated electrode

**Fig. 11.18** *Electrolyte flow methods in ECM*

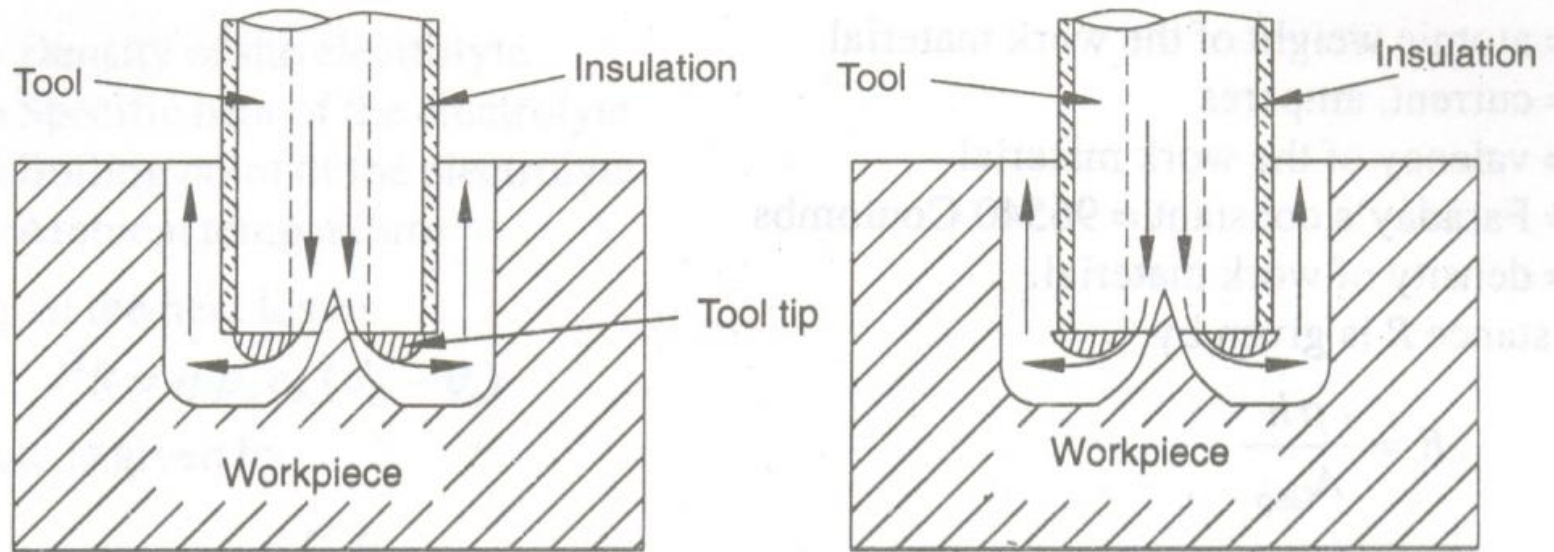

Streamlined electrolyte flow

**Fig. 11.19** *Electrolyte flow methods in ECM*

Reverse flow would be useful since it decreases the metal removed, by leaving a large slug at the centre of the hole produced; Also best arrangement for the electrolyte flow since the finished surface is not affected by the electrolyte with the metal debris

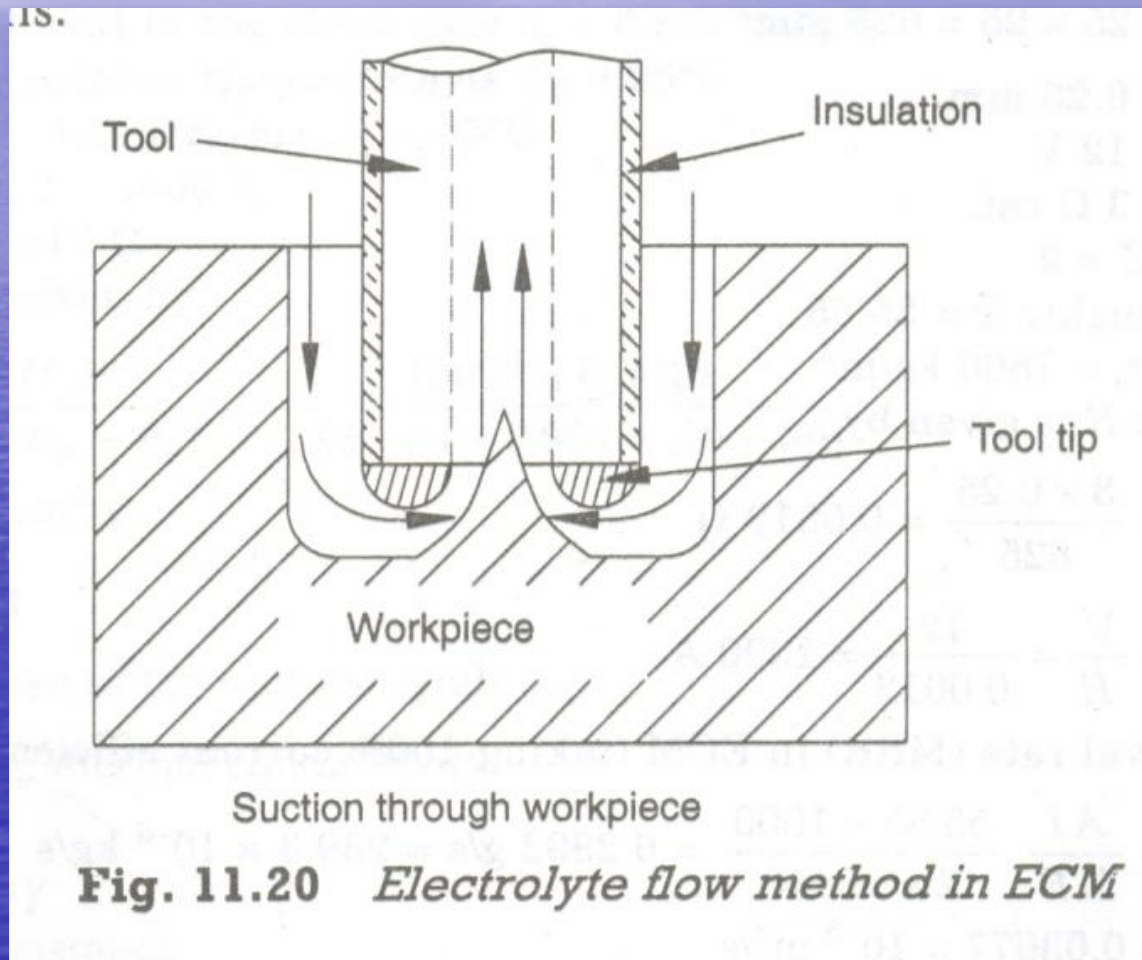

Initial shape of the component generally may not comply with the tool shape and only a small fraction of the area is close to the tool surface at the beginning – the problem of supplying the electrolyte over such area is overcome by using the flow restriction technique

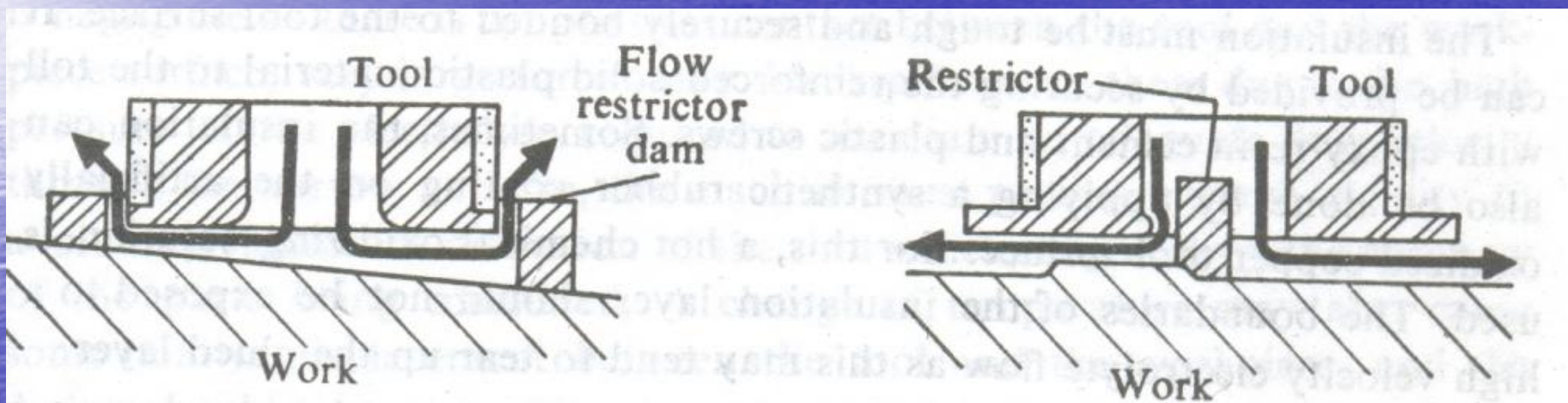
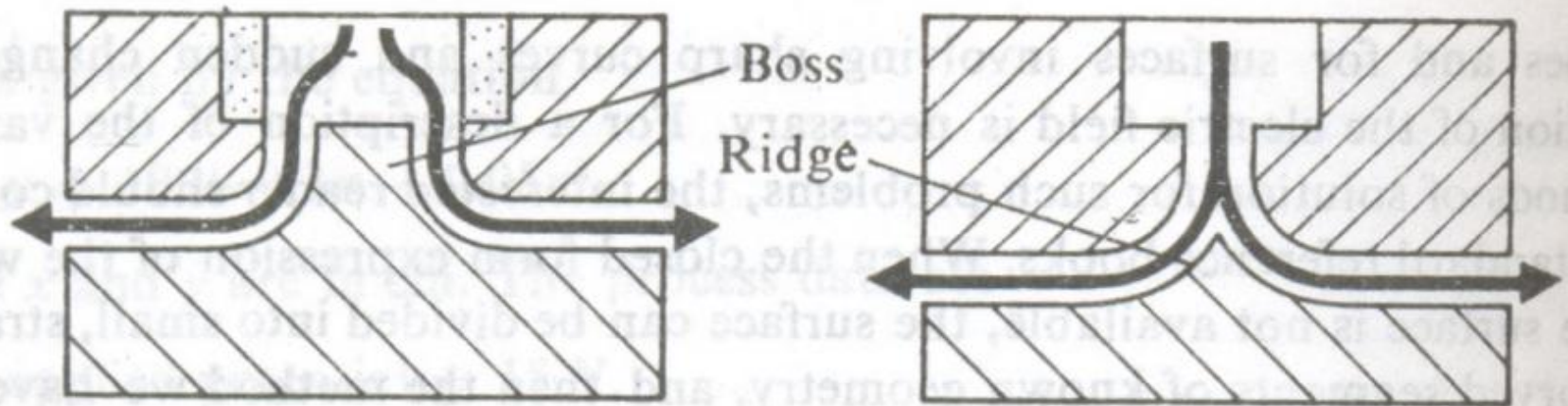

Fig. 6.46 Control of electrolyte flow by restrictor dams.



In many situations, when the initial work conforms to the tool shape, the machining process itself causes the formation of boss and ridge in the workpiece, which helps in the proper distribution of the electrolyte flow



(a) Boss formation

(b) Ridge formation

Fig. 6.42 Formation of boss and ridge on machined surface.

Tool with an electrolyte supply slot is simple to manufacture, but such a slot leaves small ridges on the work. However, the ridges can be made very small by making the slot sufficiently narrow

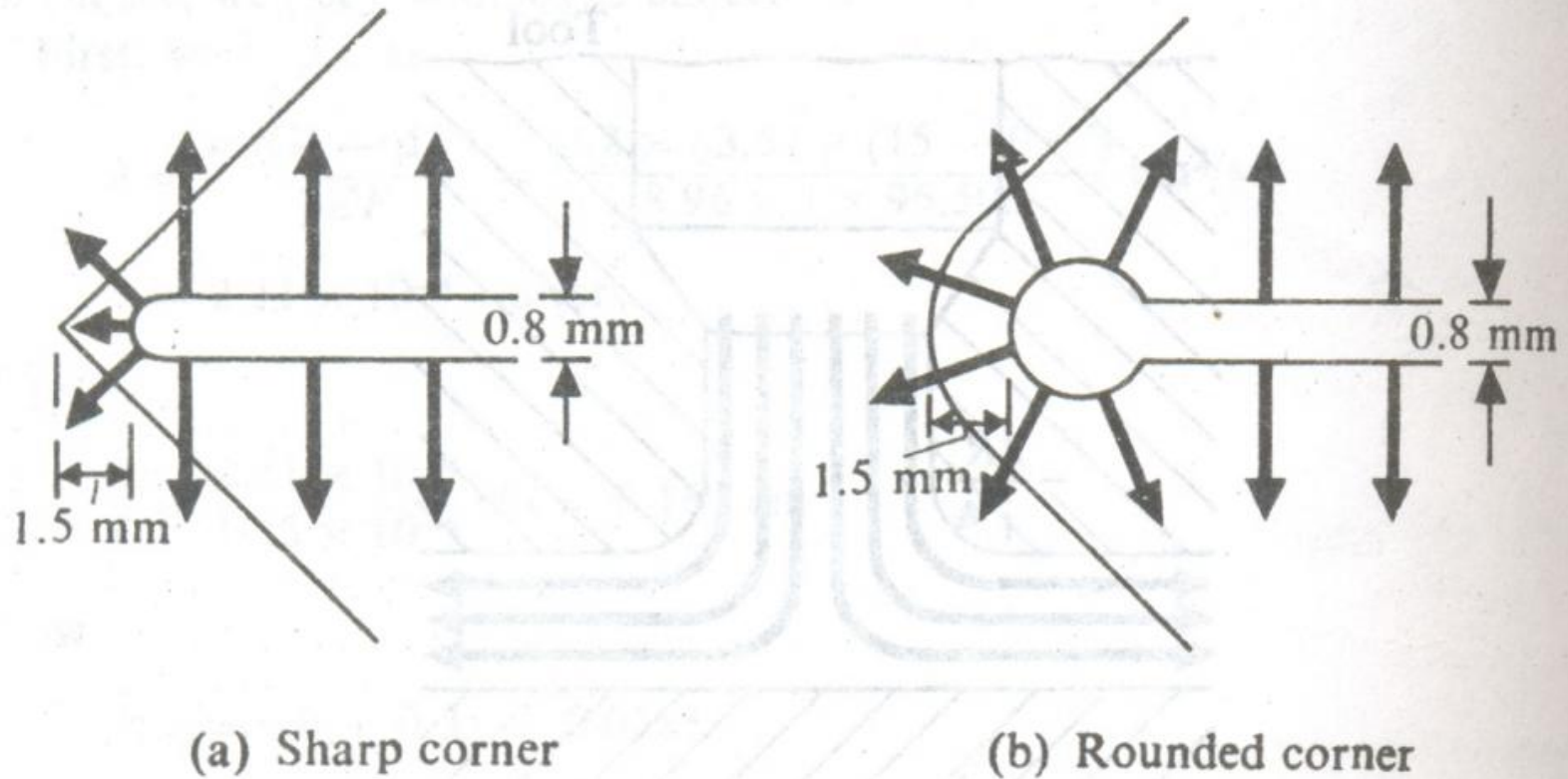
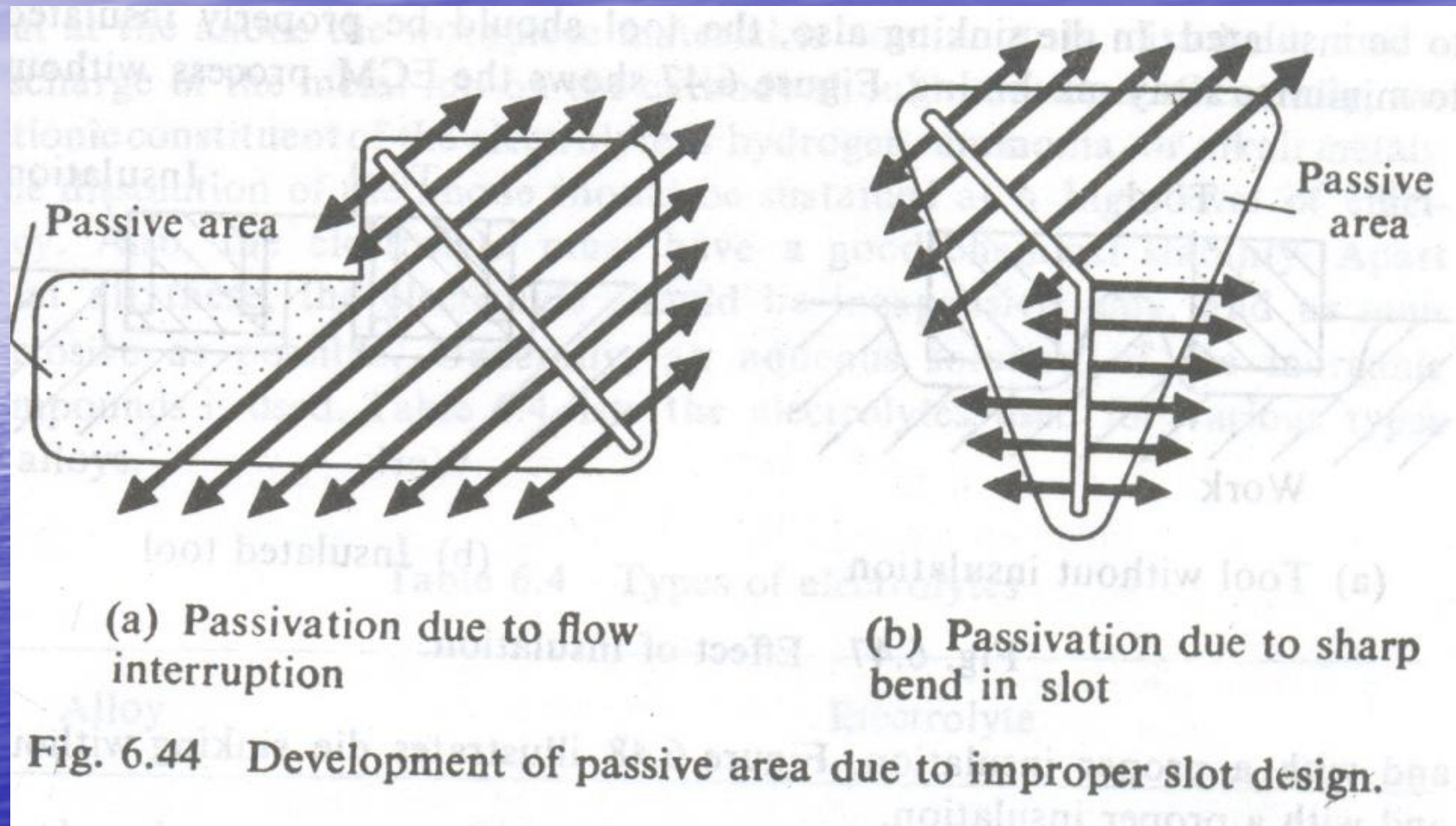
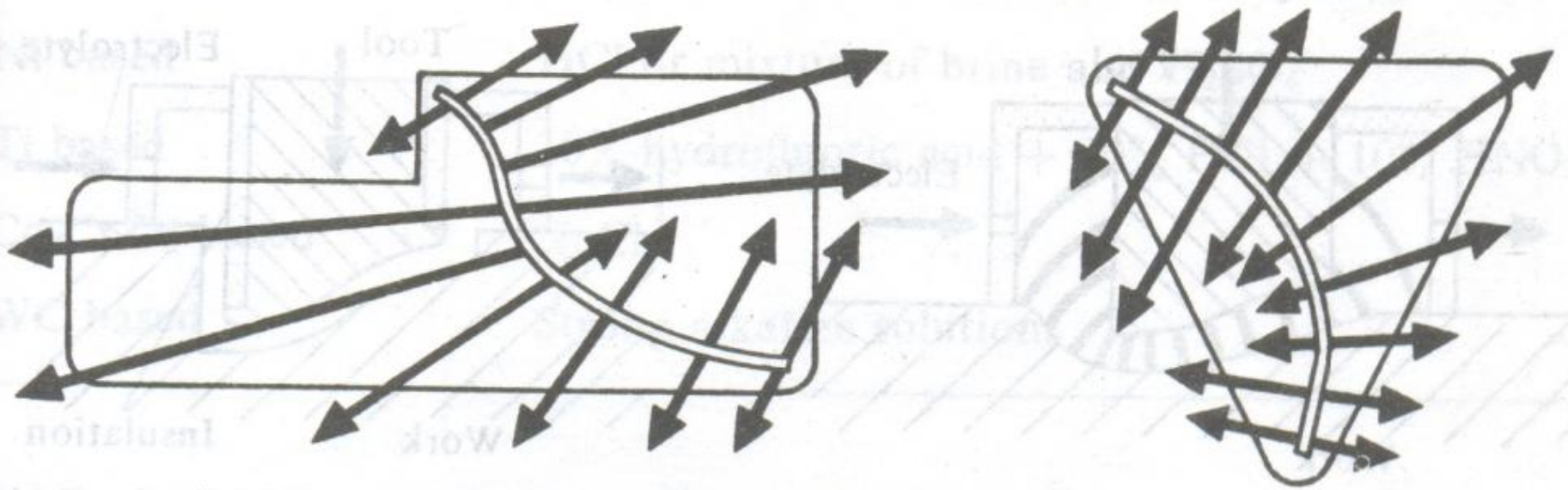

Fig. 6.43 Slot in tool face with sharp and rounded corners.

The flow from a slot takes place in a direction perpendicular to the slot and the flow at the end is poor – therefore the slot is terminated near the corners of the w/p surface

The shape and location of the slot should be such that every portion of the surface is supplied with electrolyte flow and no passive area exists



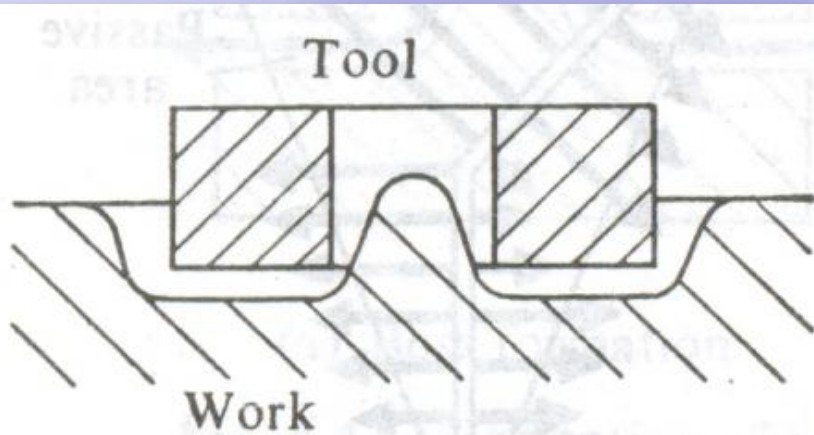

**Fig. 6.45** Slot design to avoid development of passive area.

# Insulation

- Insulation is important in the control of the electrical current
- Desirable qualities of insulation:
  1. Adhesion to the tool: preformed insulation can be held to the tool by shrinkfitting, adhesives or fasteners
  2. Sealing without pores or leaks that could cause stray machining by current leakage
  3. Adequate thickness
  4. Smoothness to avoid disturbing the flow of electrolyte
  5. Resistance to heat for continuous service at 200°C without breakdown
  6. Durability to resist wear in guides and fixtures
  7. Chemical resistance to the electrolyte
  8. High electrical resistivity
  9. Uniform application to minimize disturbance of the flow of electrolyte and to prevent interference
  10. Low water absorption
- Generally the simplest method of applying insulation is by spraying or dipping
- Teflon, urethane, phenolic, epoxy, powder coating and other materials are commonly used for insulation
- Sprayed or dipped coatings of epoxy resins are among the most effective insulating materials
- For optimum effectiveness, these coatings should be used with a protective lip on the tool to protect the edge of the insulation from the flow force of the electrolyte

## ECM process without and with a proper insulation



(a) Tool without insulation

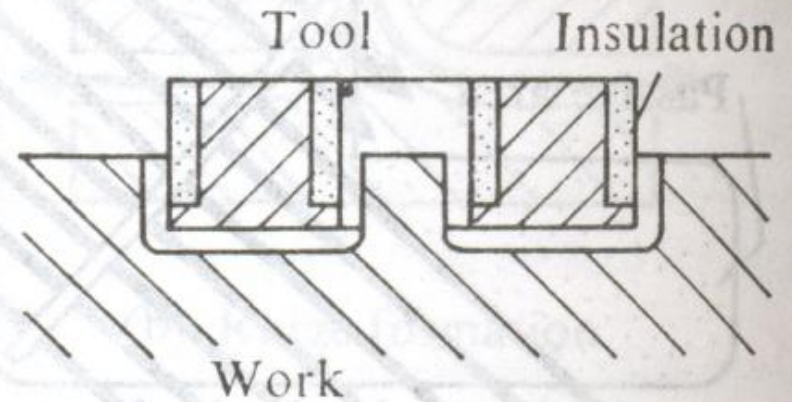

(b) Insulated tool!

## Die sinking without and with a proper insulation

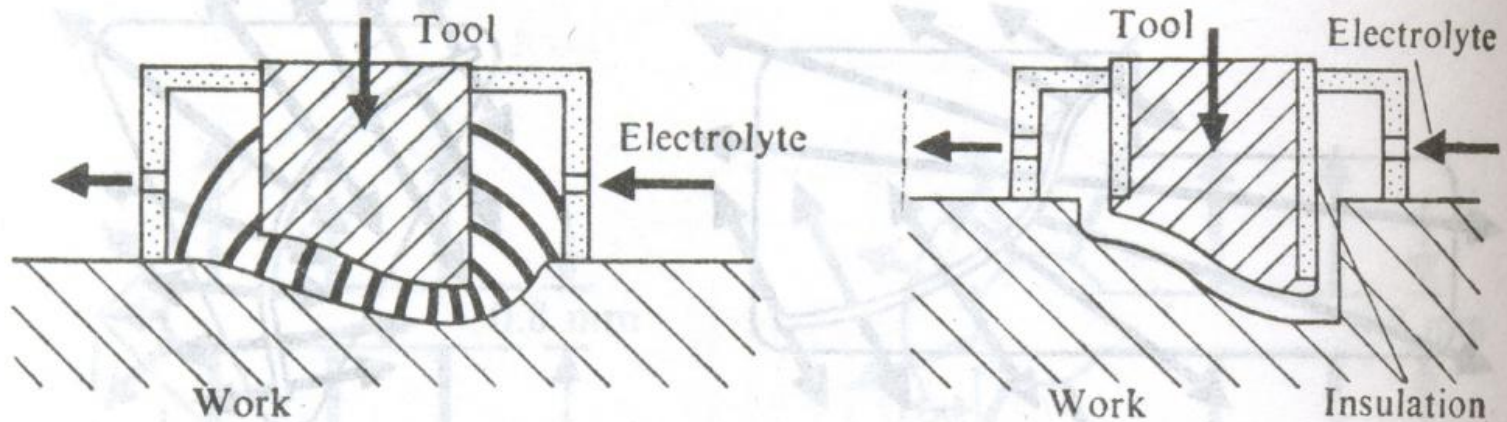

(a) Tool without insulation (b) Insulated tool

# Process parameters

- MRR with ECM are sufficiently large and comparable with that of the conventional methods
- The rate of material removal in ECM is governed by Faraday's law and is a function of current density.
- Current density is not only controlled by the amount of current that the power supply is delivering, but also by the size of the IEG
- A small IEG results in the highest current density. However, when its very small, there is a danger of sludge particles bridging the gap and causing a short circuit
- When the gap is too large, current density is reduced, resulting in a poor surface finish and decreased MRR
- Other variables that affect the current density and the MRR are:
  1. Voltage
  2. Feed rate
  3. Electrolyte conductivity
  4. Electrolyte composition
  5. Electrolyte flow
  6. Workpiece material



# Voltage

- Voltage across the cutting gap influences the current and the MRR and is controlled in most ECM operations
- Low voltage decreases the equilibrium-machining gap and results in a better surface finish and finer tolerance control
- Increased current leads to electrolyte heating – low temperature of the electrolyte is conducive for a better surface finish and tolerances

# Feed rate

- Feed rate determines the current passed between the tool and the work
- As the tool approaches the work, the length of the conductive path decreases and the magnitude of the current increases
- High feed rate results in higher MRR
- High feed rates also decreases the equilibrium machining gap resulting in improvements of the surface finish and tolerance control
- Most rapid feed possible is not only highly productive but also produces the best quality of surface finish
- At slower feed rates, the MRR decreases as the gap increases resulting in the rise of resistance and drop in the current
- Limitations of feed rate are removal of hydrogen gas and products of machining;
- Also higher feed rate requires fine filtering

# Electrolyte conductivity

- Affects the resistance across the gap
- Increasing the concentration will cause conductivity to rise
- Temperature increases of the electrolyte also increases conductivity
- Low concentration and low temperature will result in lower MRR

# Electrolyte composition

- Composition directly influences conductivity, MRR and surface characteristics
- Parameters used for a given application may not yield the same ECM results if a different type of electrolyte is used
- Normal development of an operation begins with the selection of the correct electrolyte. The other parameters and the cathode are adjusted to get the desired result

# Electrolyte flow rate

- The velocity and the electrolyte flow through the gap is also an important parameter affecting the surface finish and MRR
- If the velocity is too low, the heat and by-products of the reaction build in the gap causing non-uniform material removal
- A velocity that is too high will cause cavitation, also promoting uneven material removal
- Increased electrolyte velocities require larger electrolyte pumps that add capital cost to the system
- Pressure control is the method of controlling the flow rate

# Advantages

- Ability to machine complex 3D curved surfaces without feed marks
- Machines complicated shapes in single pass
- Capable of machining metals and alloys irrespective of their strength and hardness
- Since metal removal is by mettalic ion exchange, there are no cutting forces and the workpiece is left in a stress free state – very thin sections can be machined
- There is little or no tool wear – so large number of components can be machined without replacing the tool
- Not subjected to high temperatures
- Burr free
- Good surface finish
- Good accuracy and tolerance
- Low machining time
- Low scrap
- Automatic operation

# Limitations

- Work must be electrically conductive
- Inability to machine sharp interior edges and corners
- Large power consumption and related problems (heavy initial investment)
- Post machining cleaning is a must to reduce the corrosion of the workpiece and ECM machine
- Tool design is complicated and needs cut and try methods to achieve the final shape
- Although the parts produced by ECM are stress free, they are found to have fatigue strength or endurance limit lowered by approximately 10-25%. So may require post treatment (shot peening) to restore the strength especially for situations where fatigue strength is critical
- Additional problems related to machine tool requirements: power supply, electrolyte handling and tool feed servo system
- High maintenance
- Can cause intergranular attack (IGA)
- High tooling and set-up costs

# Applications

- Aerospace industries: machining gas turbine blades, airframe component fabrication, honey-comb aircraft panels, jet engine blade airfoils
- Manufacture of general machine parts: thin wall mechanical slotting, difficult to machine hollow shafts, chain pinions, internal profile of internal cams, driving joints, pump glands and impellers, connecting rod, hydraulic spools, gear wheels
- Facing and turning complex 3D surfaces
- Die sinking, particularly deep narrow slots and holes
- Profiling and any odd shape contouring
- Multiple hole drilling
- Trepanning
- Broaching
- Deburring
- Grinding
- Honing
- Cutting off



# ECMed bottom contour of a deep hole

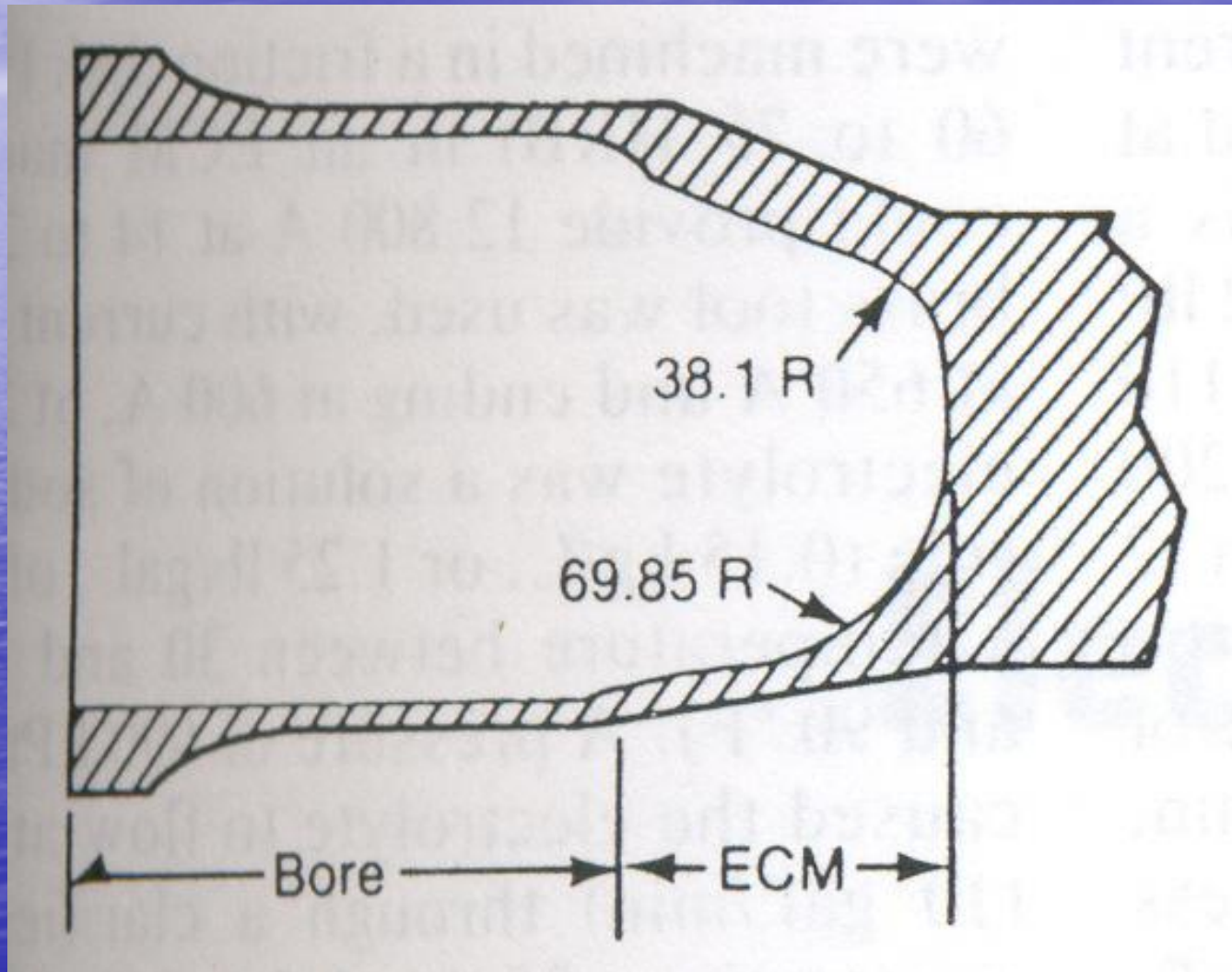

# Airfoils machined directly on a compressor disk

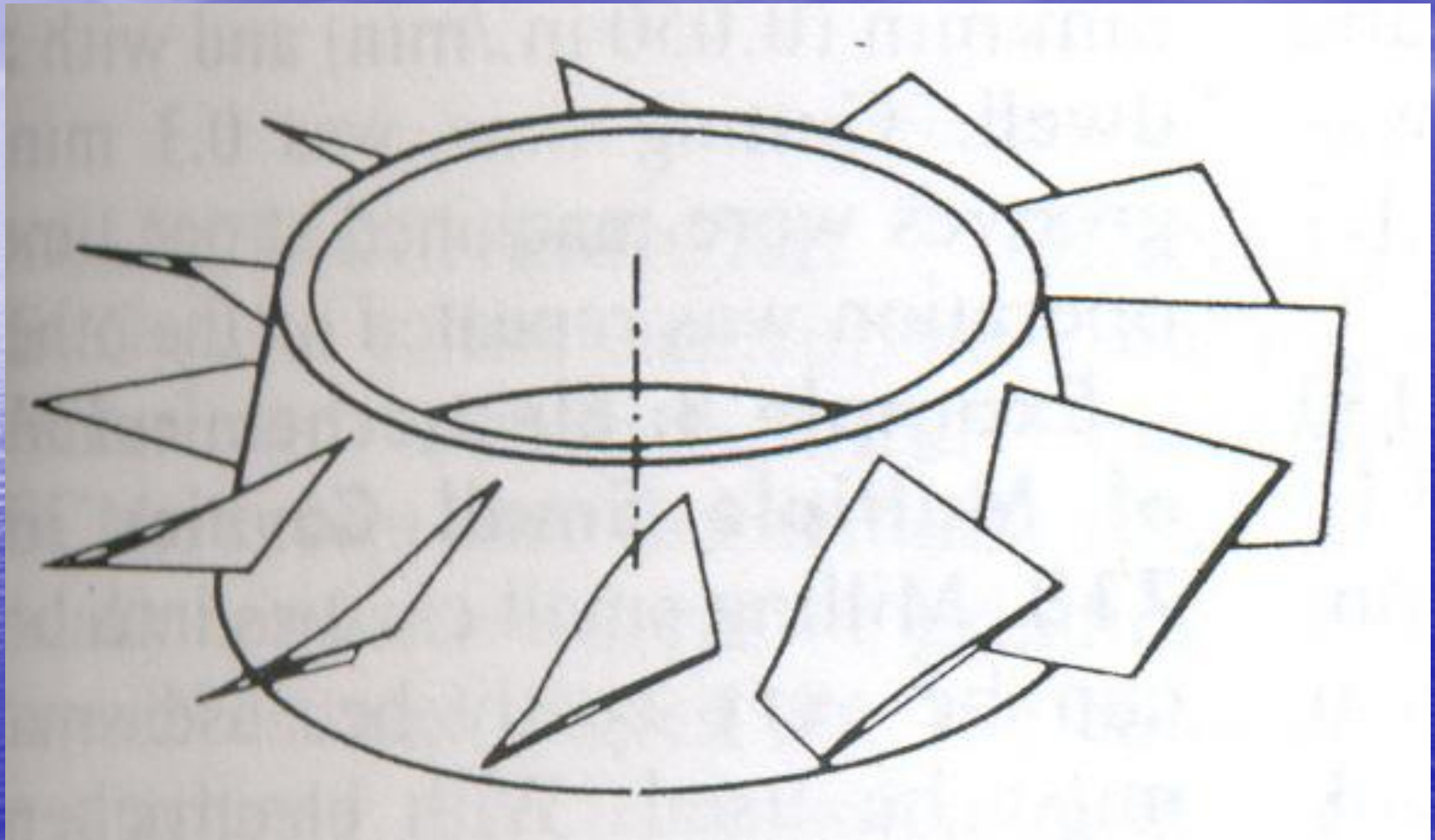

# Finishing of a conical hole in a nozzle

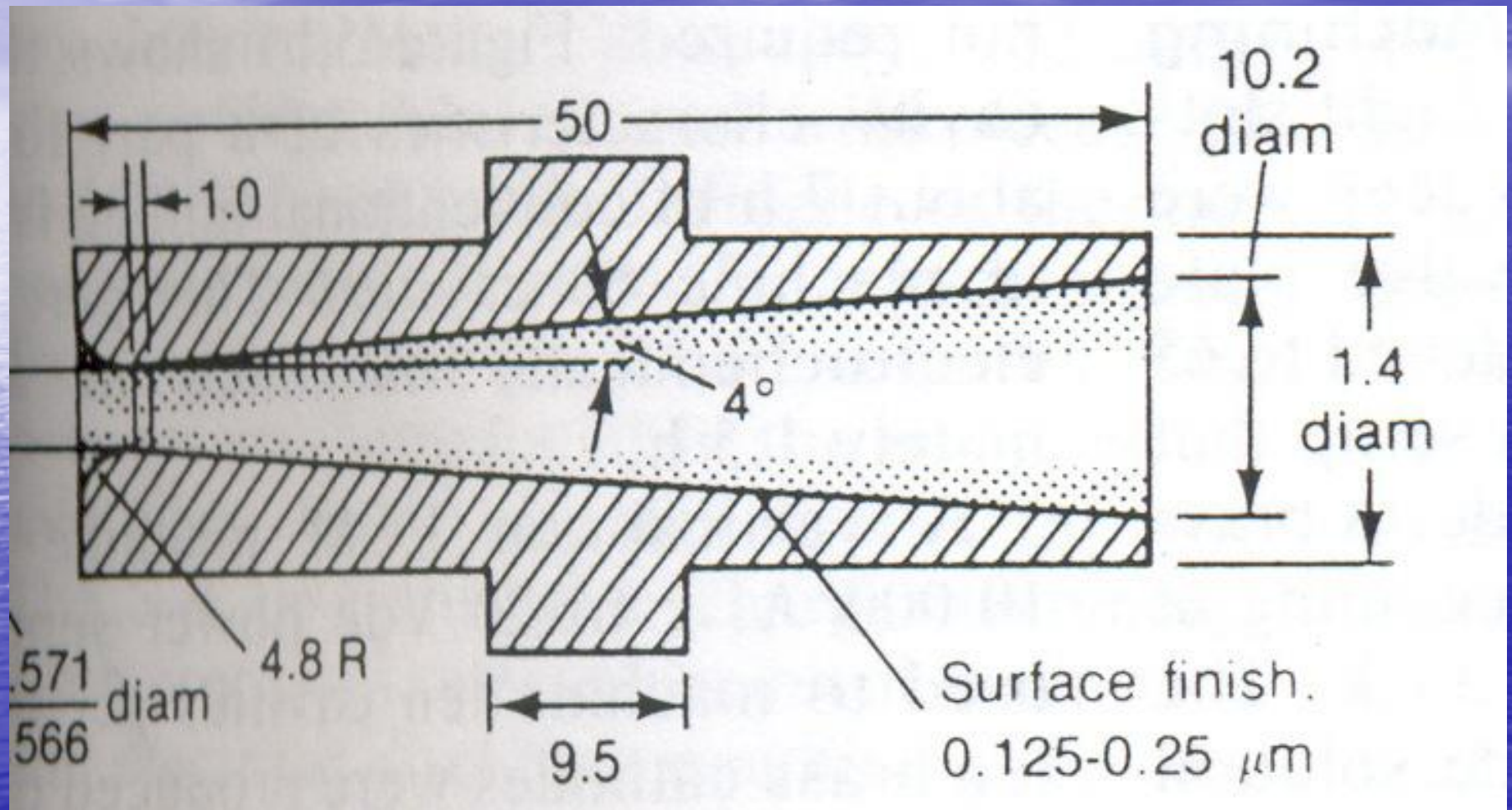

# Machining a thin-wall casing with embossments

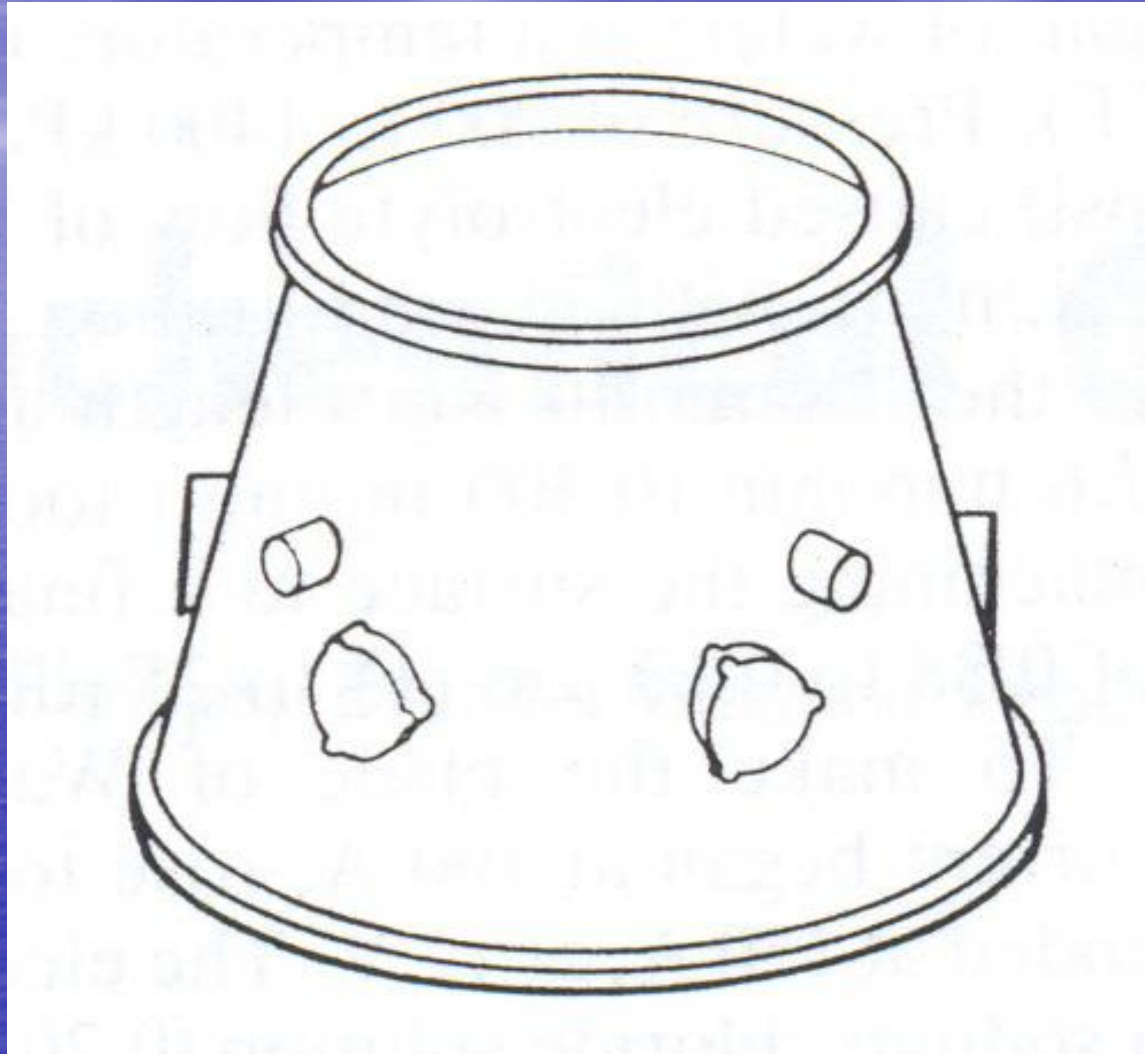

## Contouring a turbine blade surface

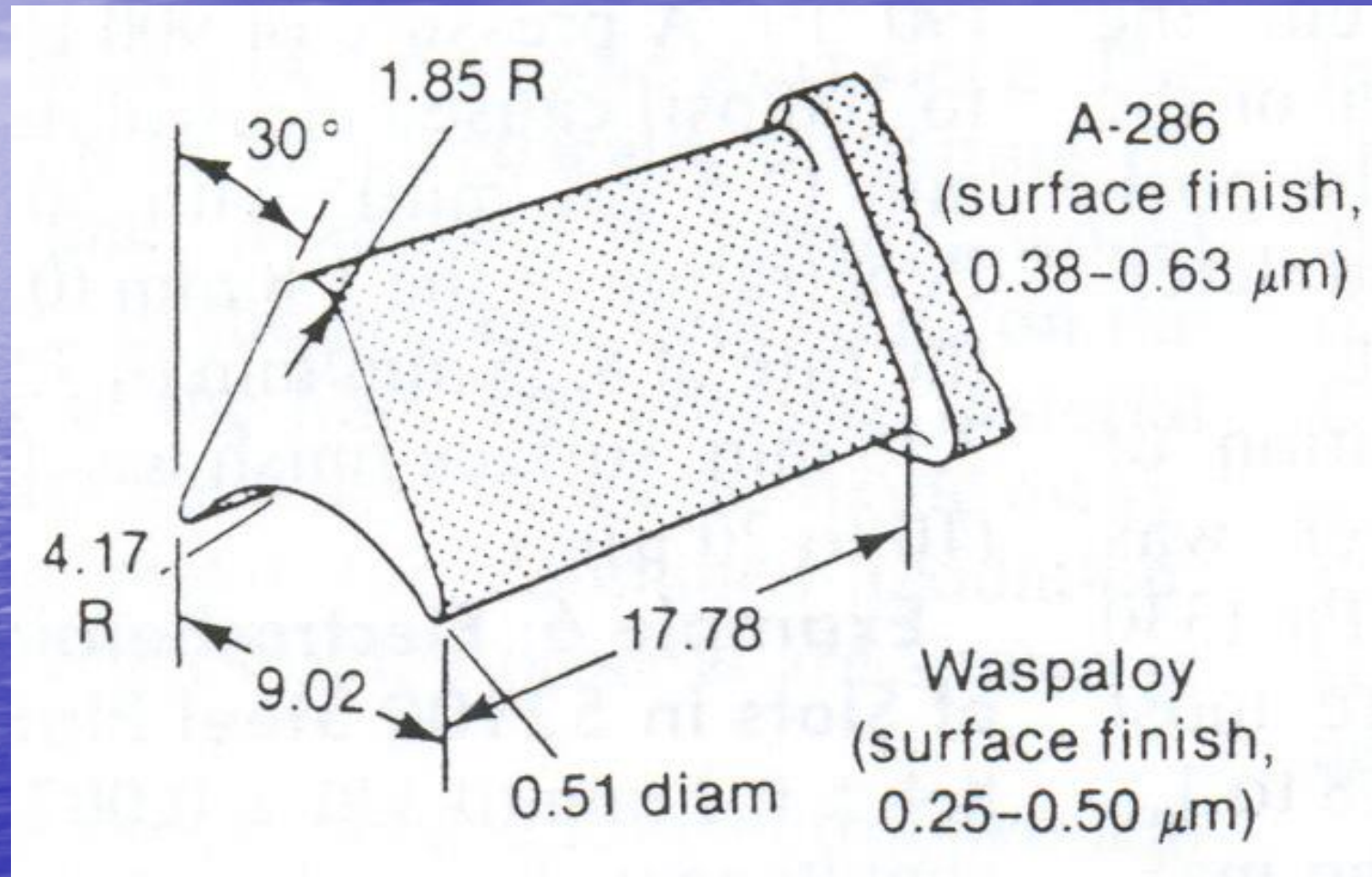

# Cutting slots in a valve plate

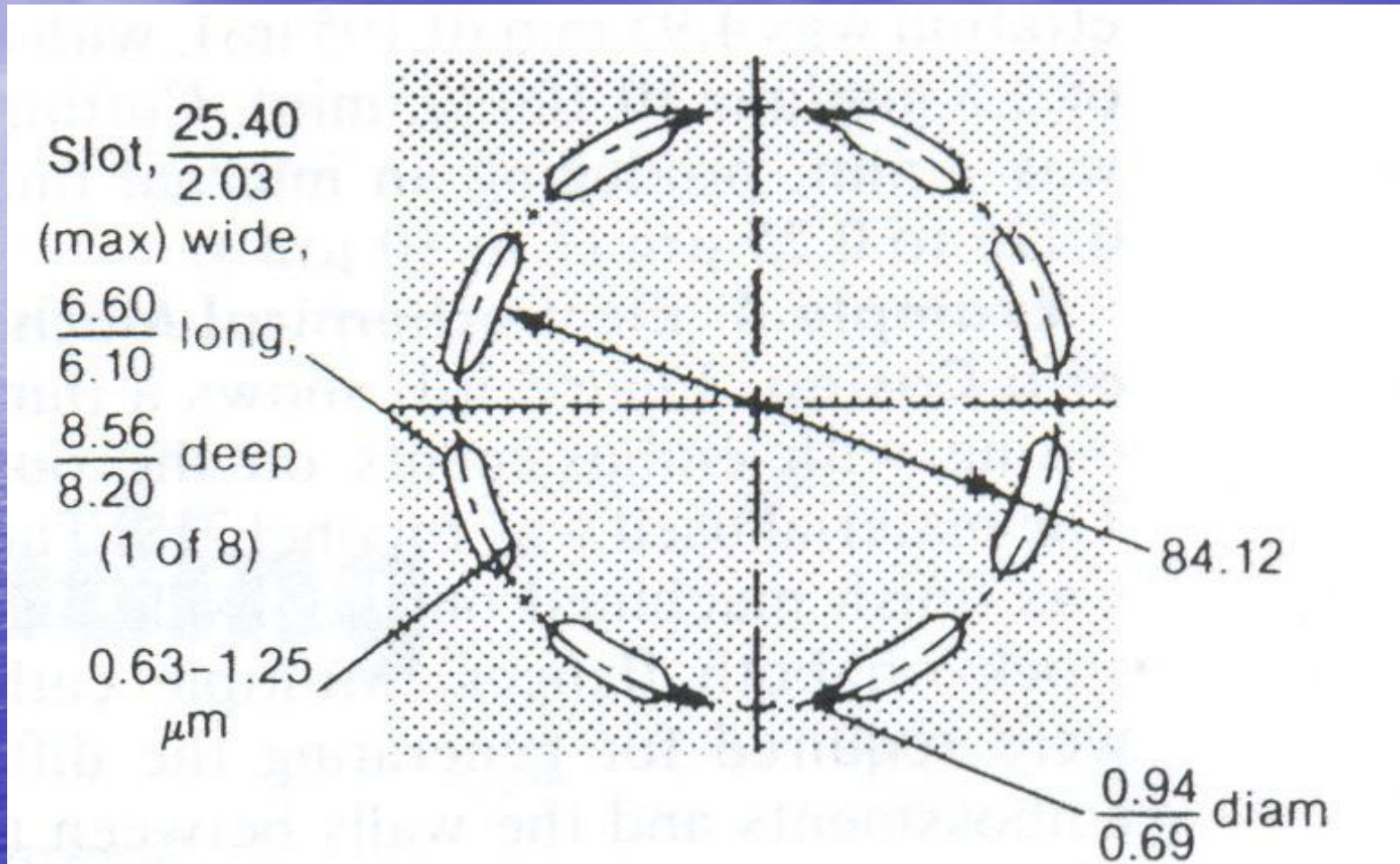

## Cutting spiral grooves in a friction plate

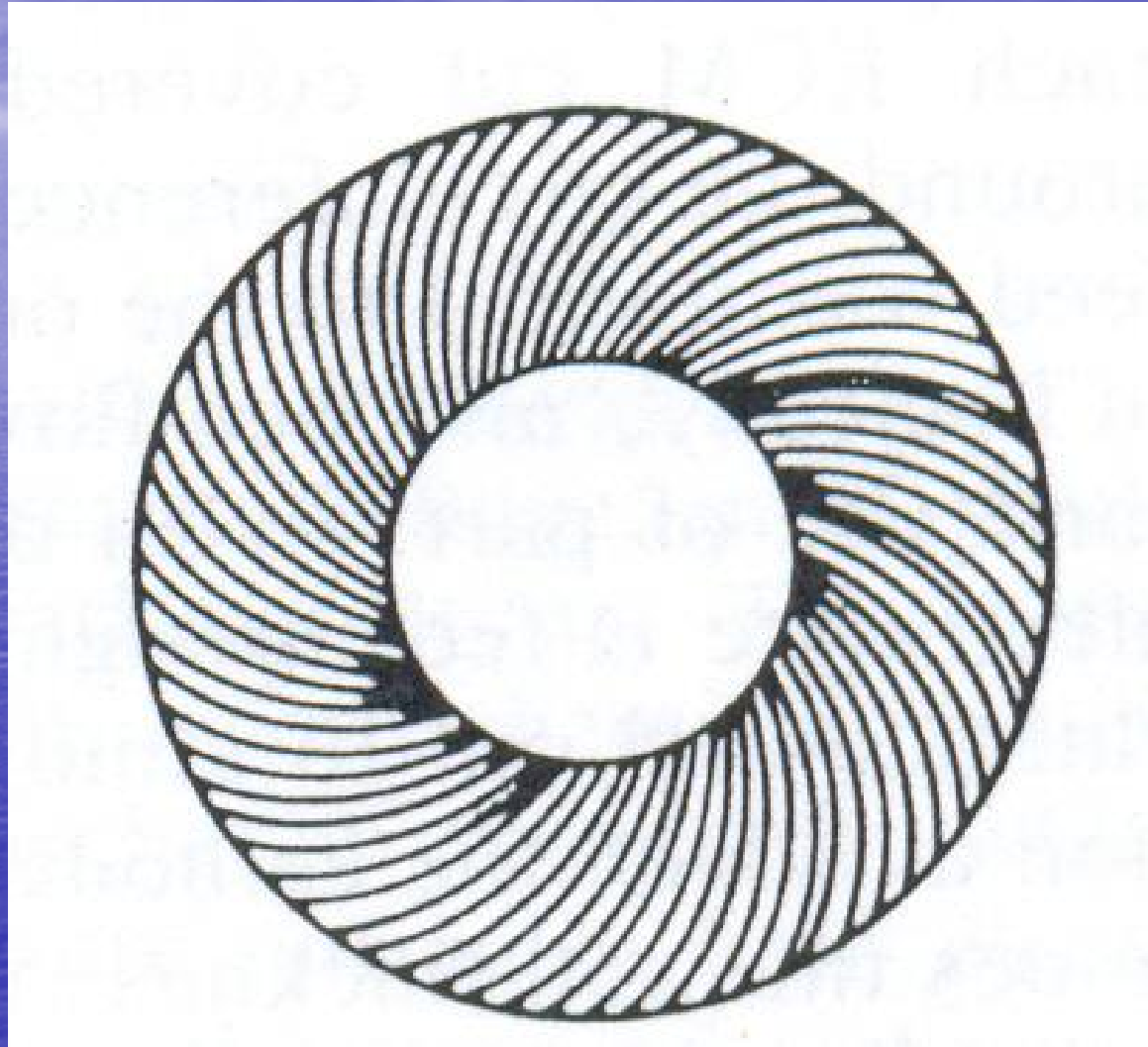

# Cutting multiple small cavities in Inconel 718

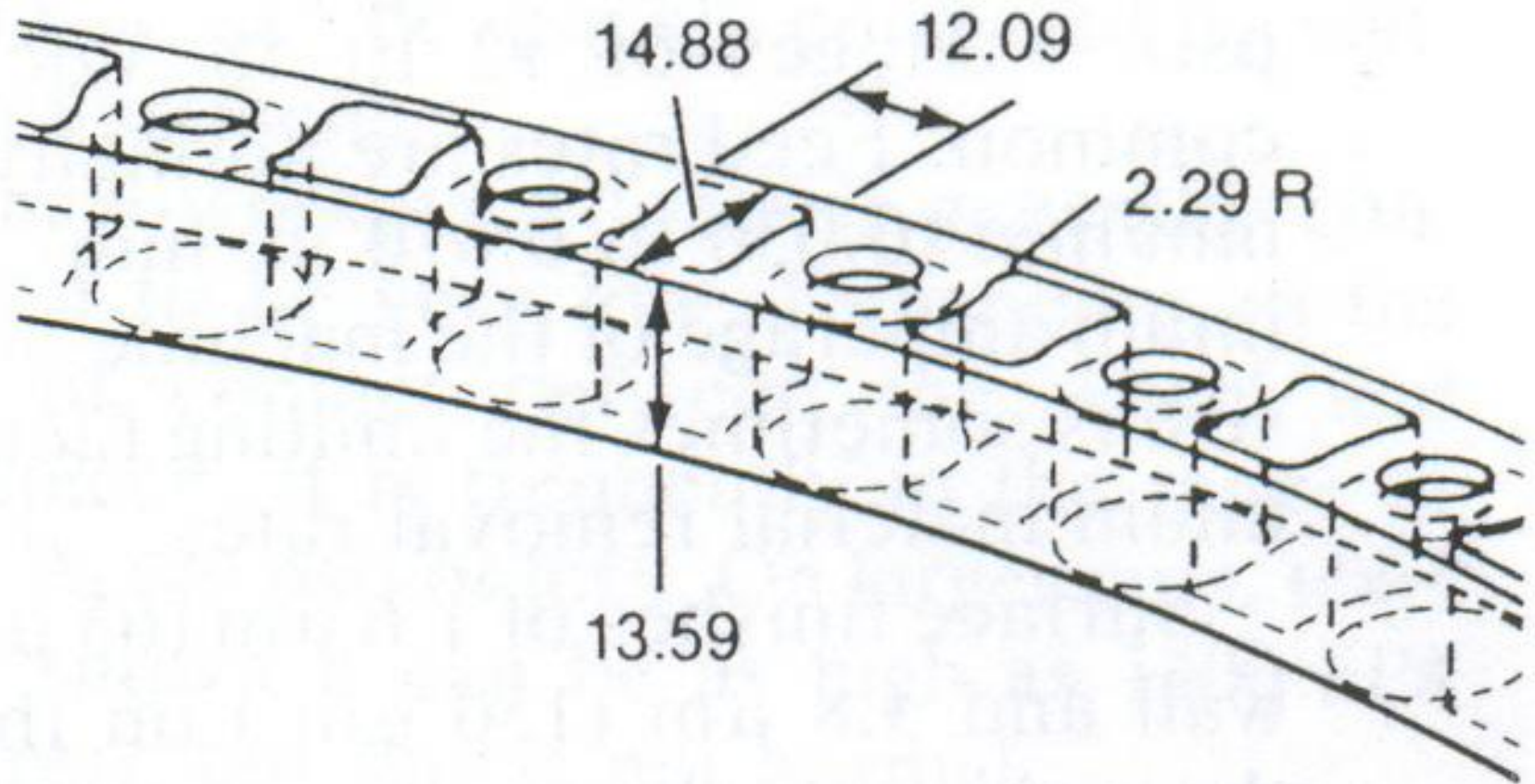



## Disc turned on ECM lathe

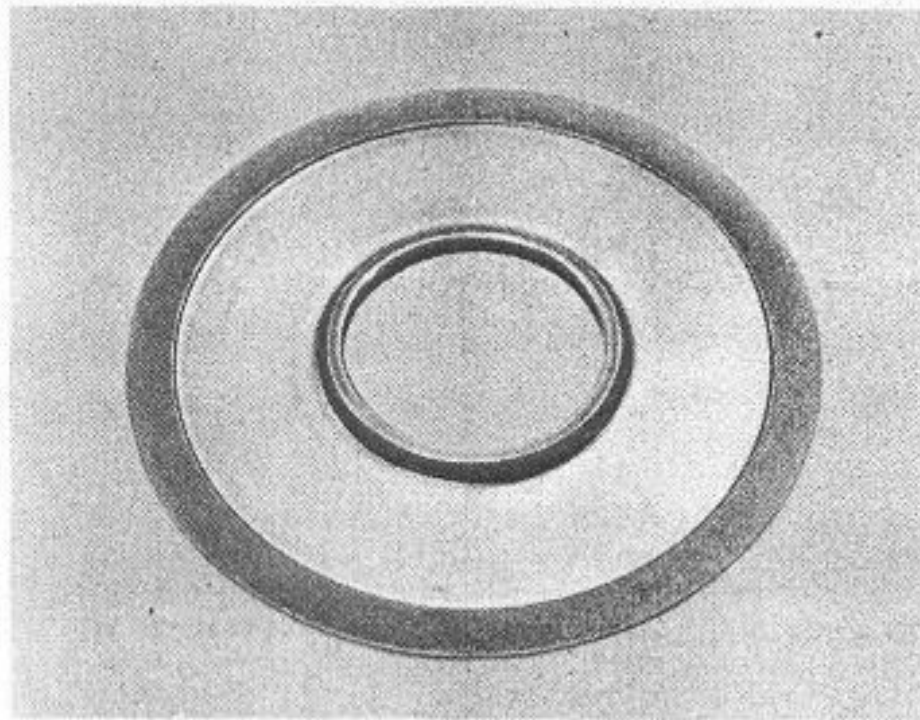

**Fig. 3-6.** Disc turned on ECM lathe to an accuracy of .0003 in. (*Courtesy, Anocut Engineering Company*)

## Die sink impression for connecting rod die

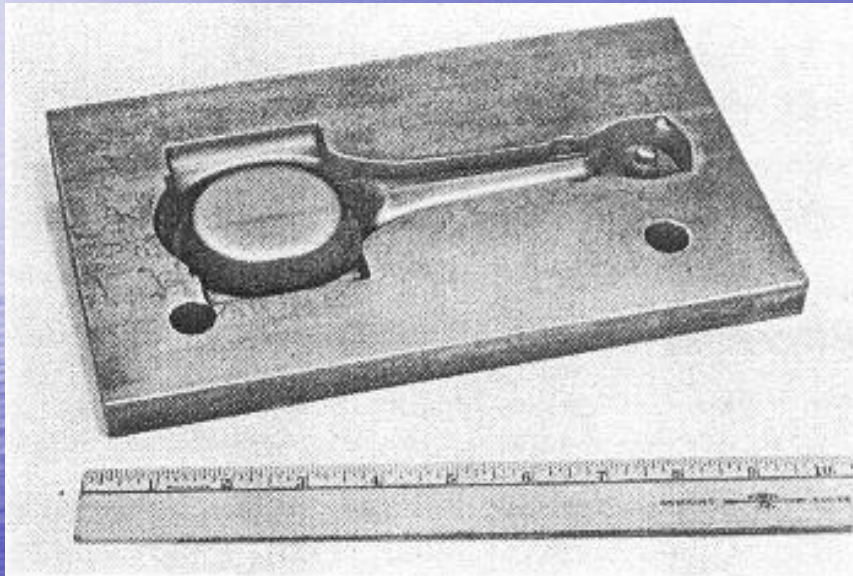

**Fig. 3-7.** Die sink impression for connecting rod die machined from a solid blank in 18 min. (*Courtesy, Anocut Engineering Company*)

## Control cam profiled by ECM

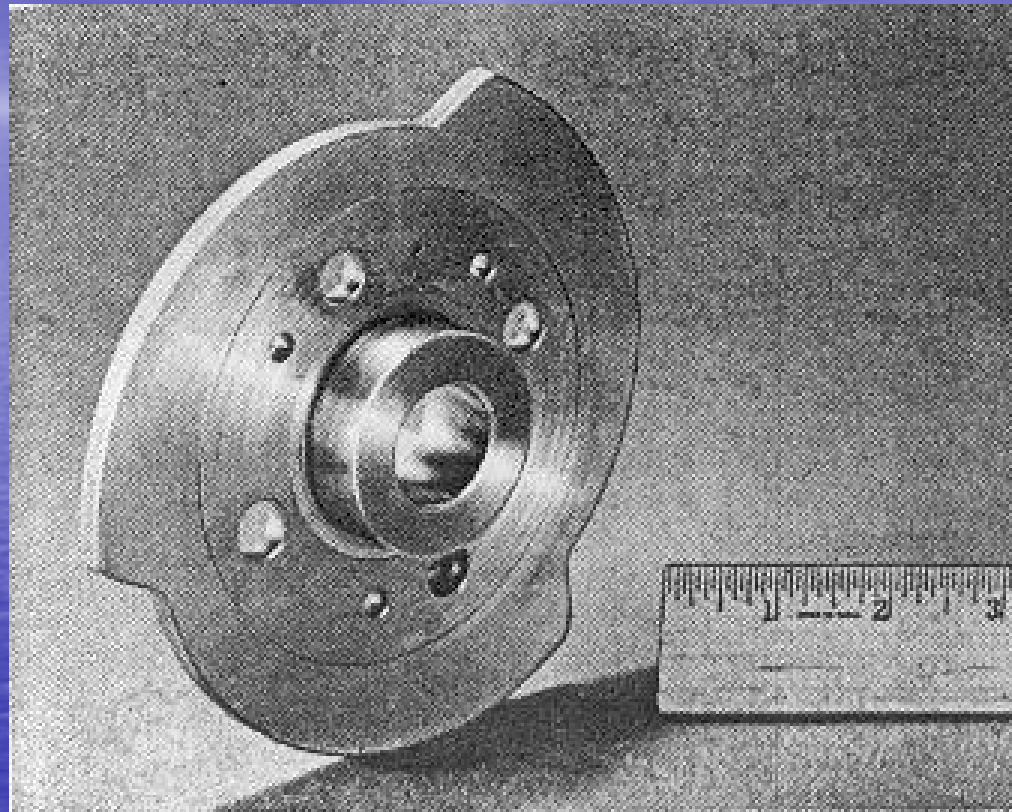

**Fig. 3-8.** Control cam profiled by ECM after hardening, with repeatable accuracy within .001 in. (Courtesy, Anocut Engineering Company)

## Stainless steel parts (illustrates repeatability)

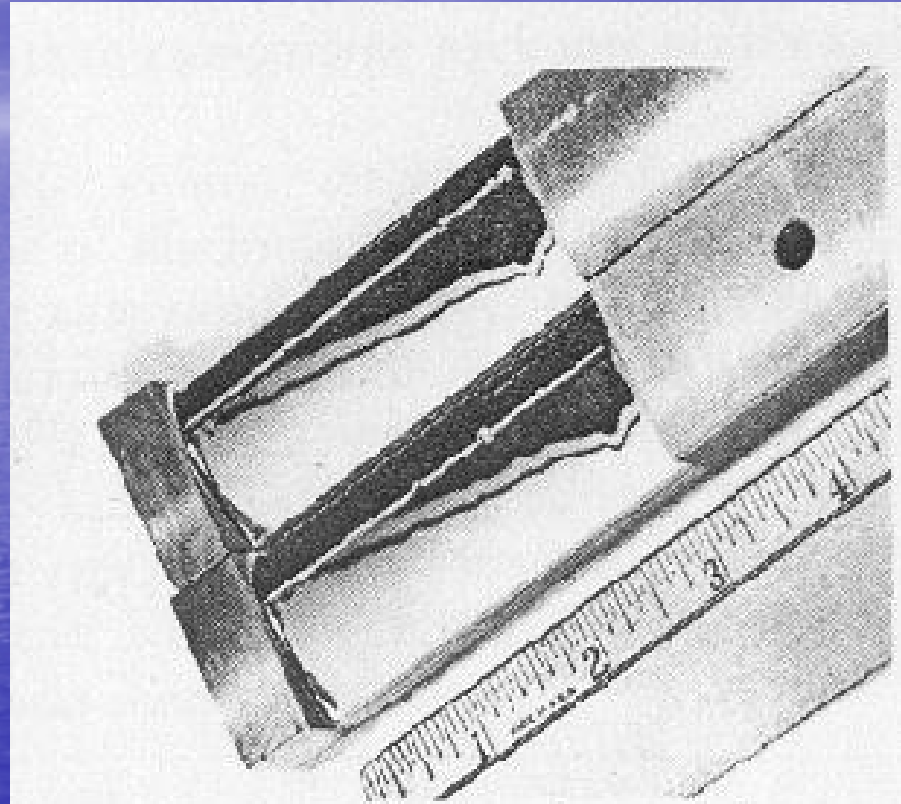

**Fig. 3-9.** Stainless steel parts electrochemically machined with same electrode (note identical reflected light patterns illustrating repeatability). (Courtesy, Anocut Engineering Company)

## Multiple hole drilling in a SS burner plate

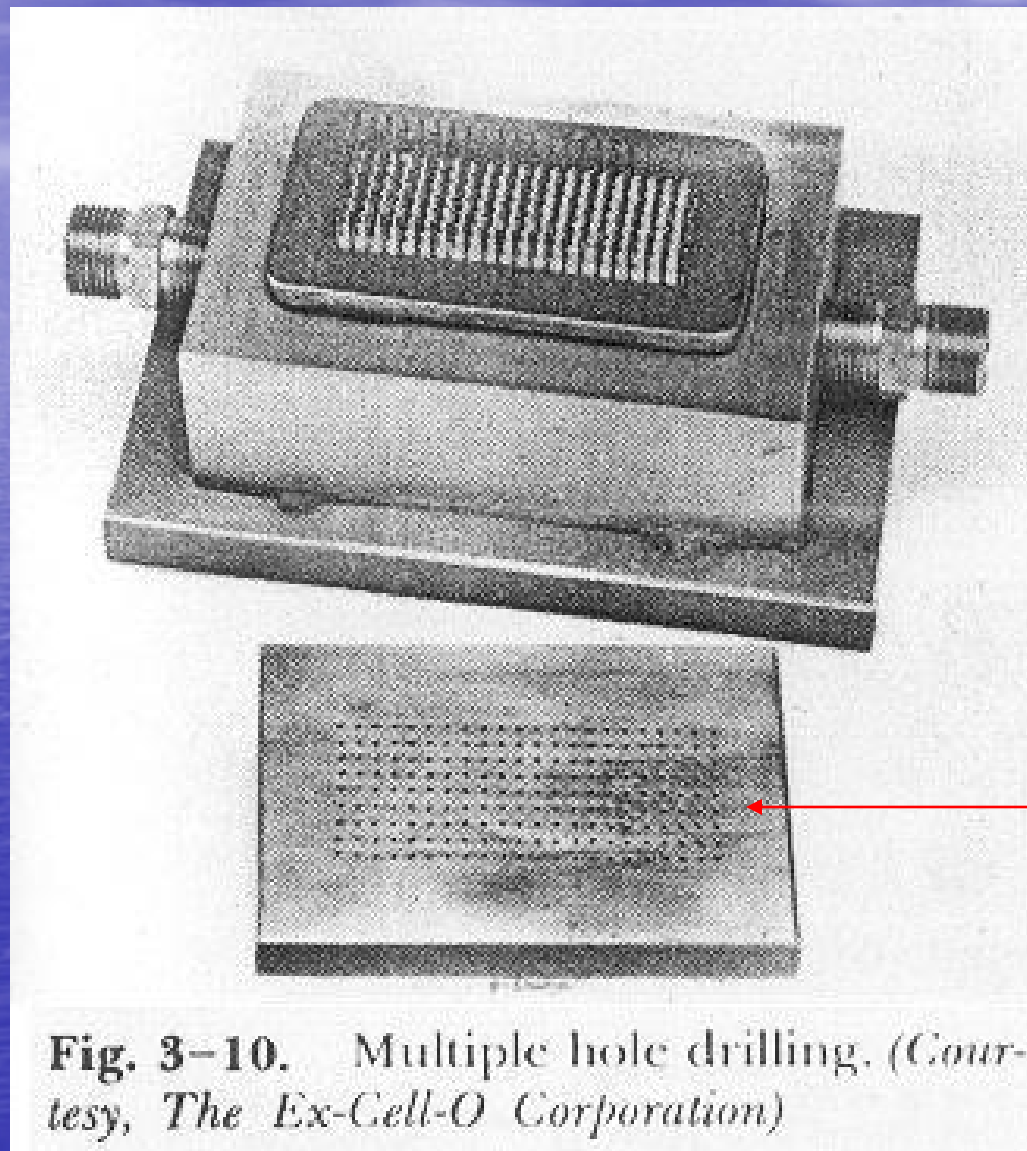

## Machining of integral valves

**Fig. 3-11.** Trepanning of nozzle valves.  
(*Courtesy, The Ex-Cell-O Corporation*)

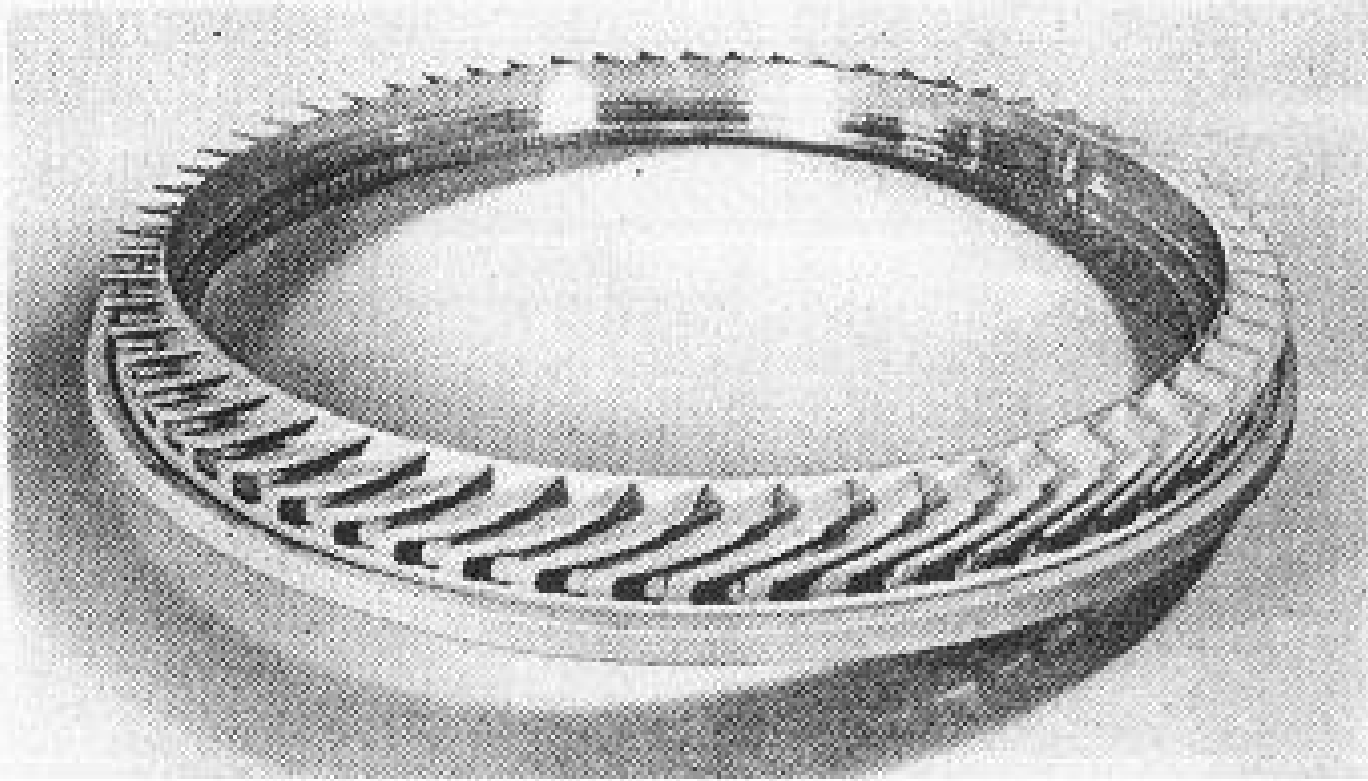

## Production of burr-free slots in a tool steel part

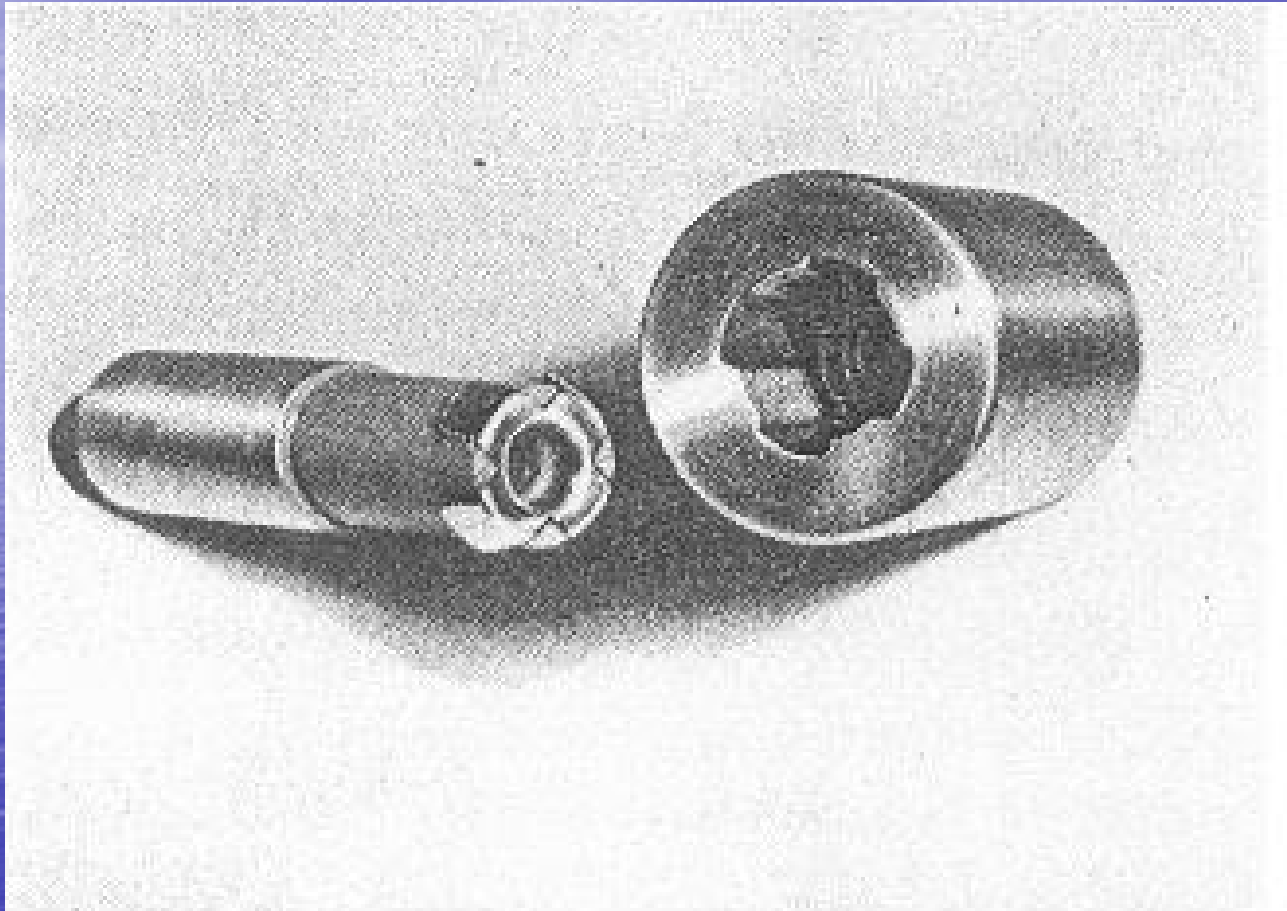

**Fig. 3-12.** Electro-broaching slots in a tool steel part. (*Courtesy, The Ex-Cell-O Corporation*)

## Cutting slots in a valve plate

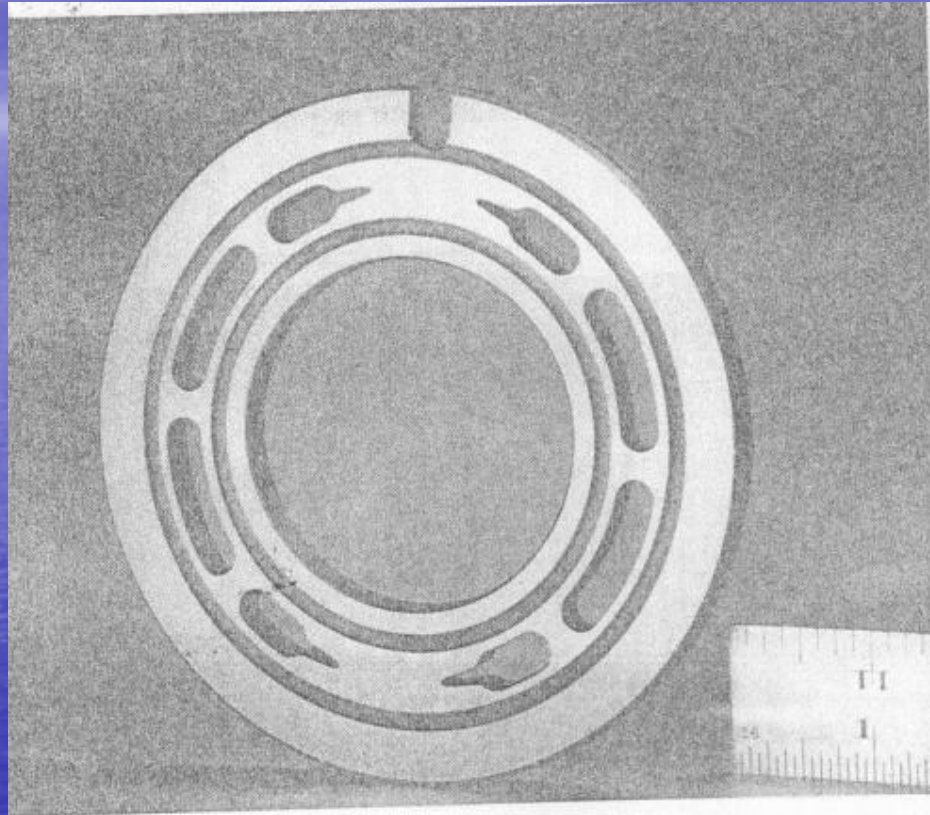

Figure 9.9 Electrochemically machined valve plate (Source: courtesy, Anocut, Inc., Elk Grove Village, Ill.).

8.4mm thick plate (hardened steel of 65HRC);  
NaCl; 1800amps; 130sec/part



# 16 pockets in a cavity machined simultaneously

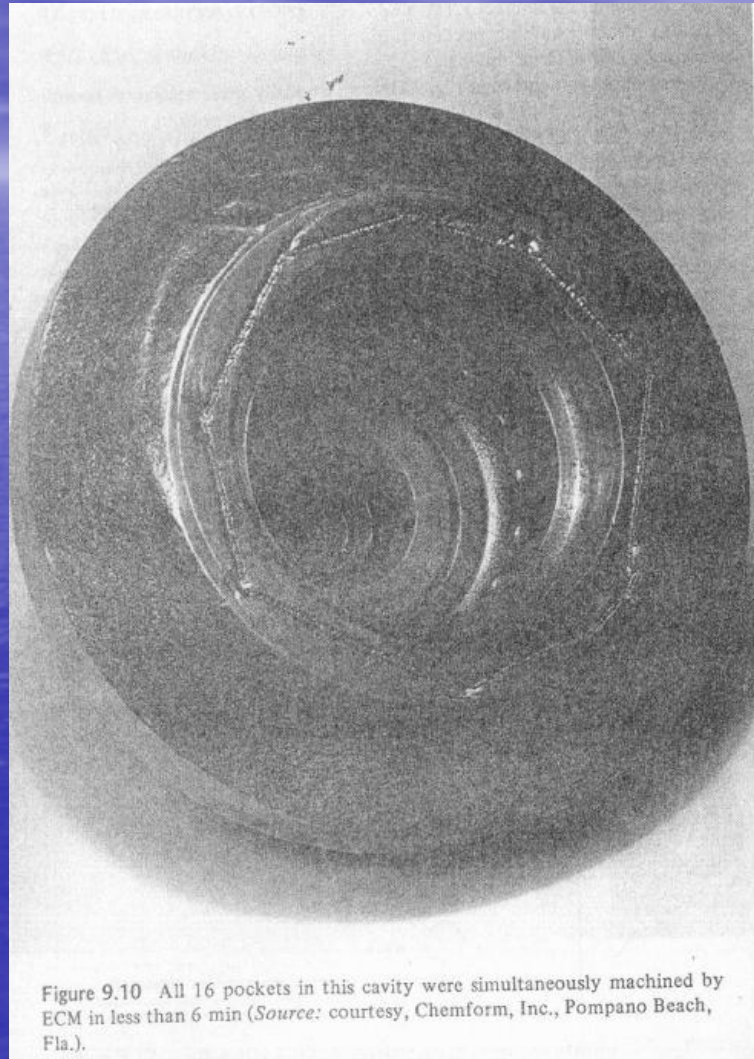

Figure 9.10 All 16 pockets in this cavity were simultaneously machined by ECM in less than 6 min (Source: courtesy, Chemform, Inc., Pompano Beach, Fla.).

Process time: less than 6 mins

## Adjusting ring and sleeve profiled by ECM

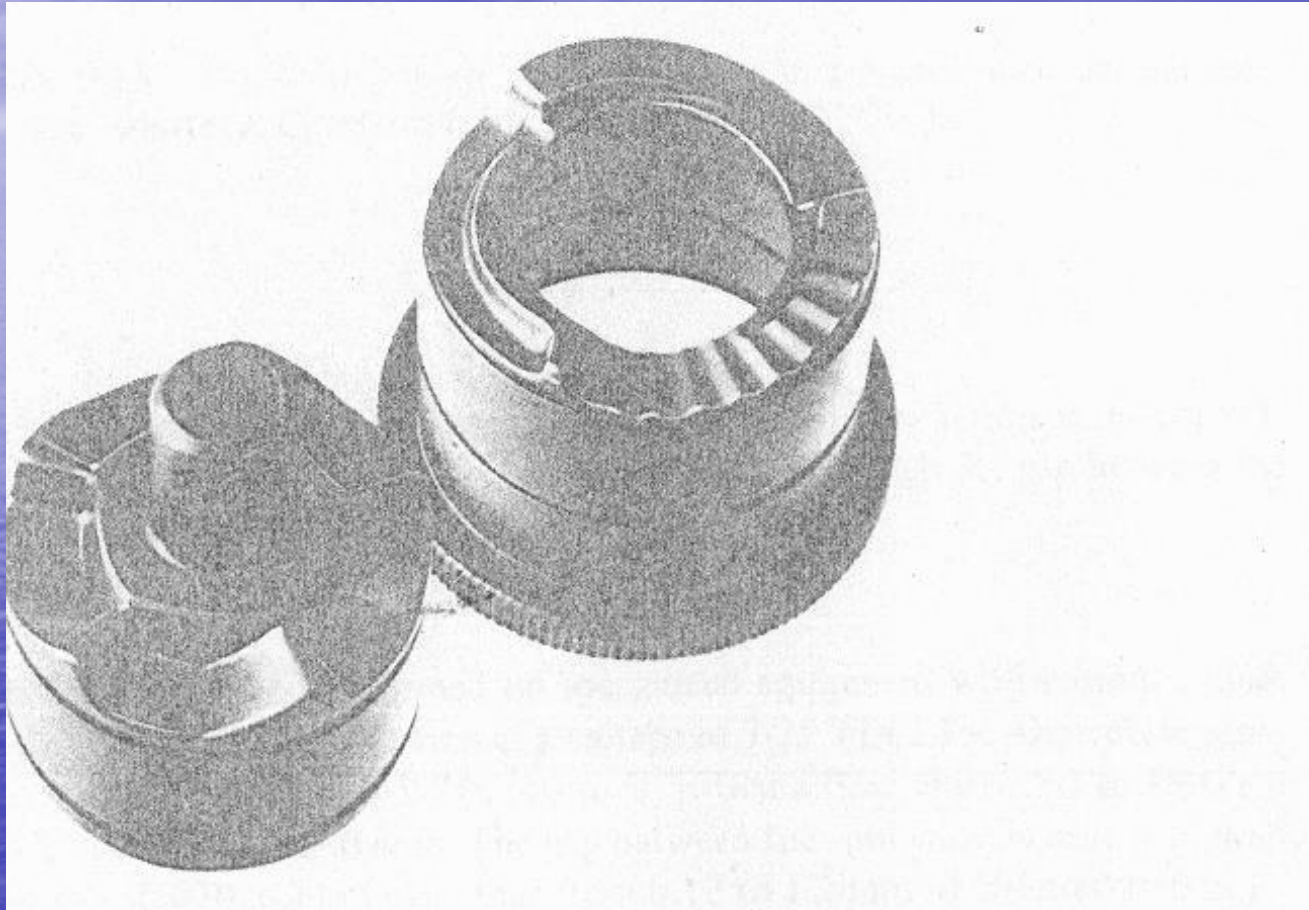

Figure 9.11 Adjusting ring and sleeve profiled by ECM (Source: courtesy, AEG-Eloterm GmbH., Remscheid, West Germany).

# Parts made by Electrochemical Machining

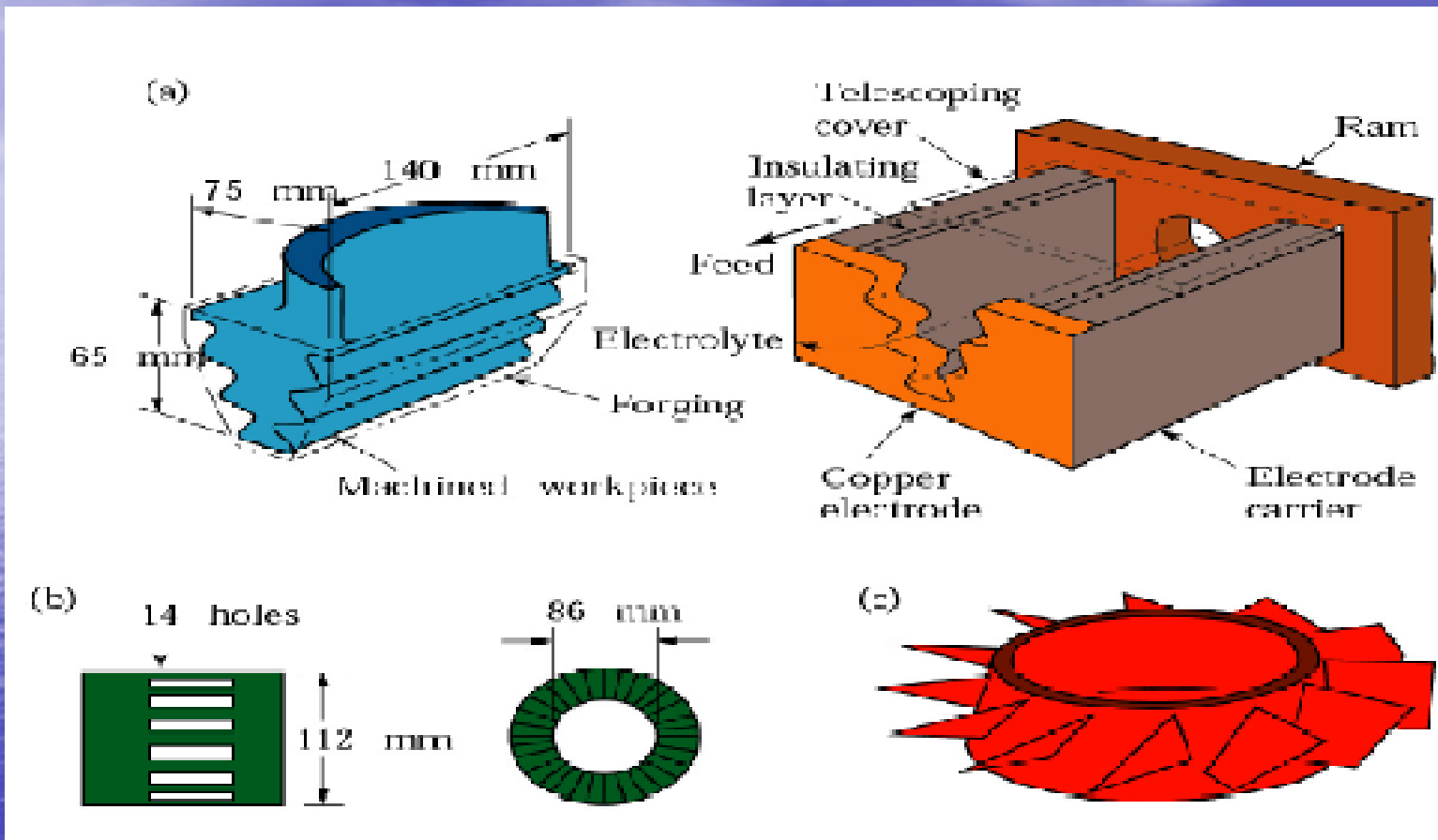

Fig : Typical parts made by electrochemical machining. (a) Turbine blade made of a nickel alloy, 360 HB; note the shape of the electrode on the right. (b) Thin slots on a 4340-steel roller-bearing cage. (c) Integral airfoils on a compressor disk.

# Biomedical Implant

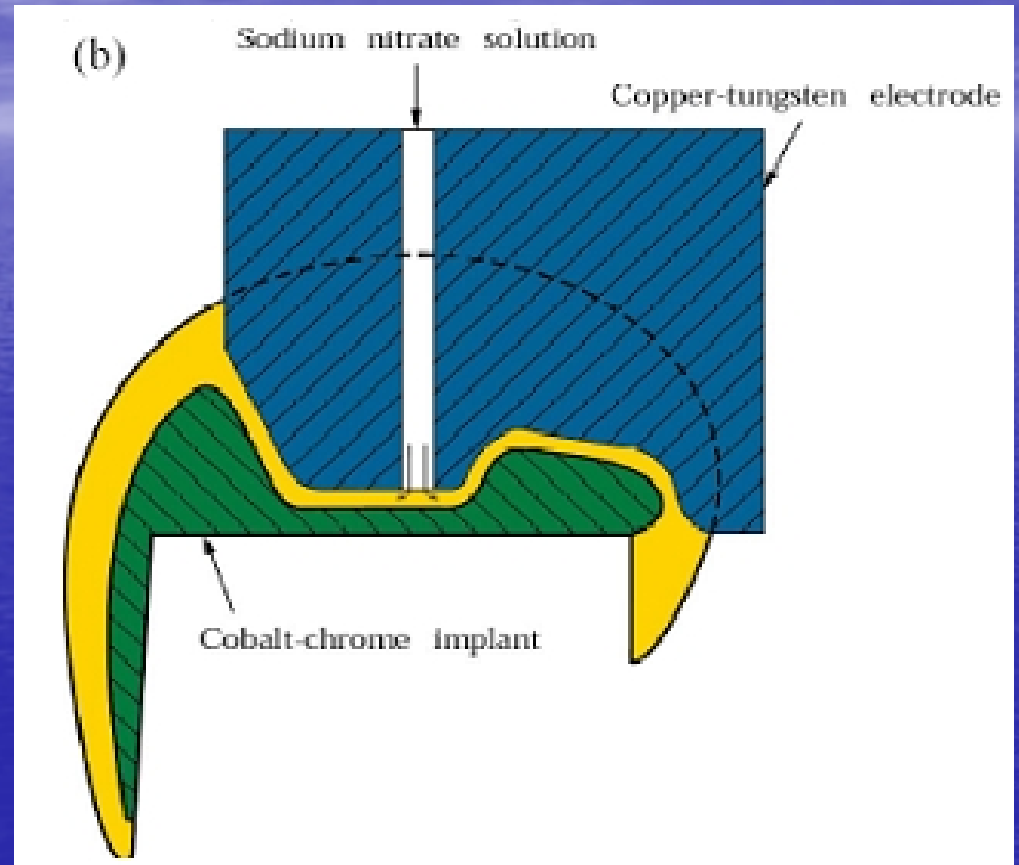

Fig : (a) Two total knee replacement systems showing metal implants (top pieces) with an ultrahigh molecular weight polyethylene insert (bottom pieces) (b) Cross-section of the ECM process as applied to the metal implant.



# Design considerations for Electrochemical Machining

- Electrolyte erodes sharp surfaces and profiles so not suited for sharp edges
- Irregular cavities may not be produced to the desired shape with acceptable dimensional accuracy
- Designs should make provisions for small taper for holes and cavities to be machined

## Pulsed electro chemical machining(PECM)

- Refinement of ECM
- Uses pulsed rather than direct
- Improves fatigue life, eliminates recast layer left on die and mold surfaces by electrical discharge machining
- Very high current densities, but the current is